

METTLER TOLEDO

Table of Contents

1	Introduction	3
1.1	Further documents and information	3
1.2	Explanation of conventions and symbols used	3
1.3	Acronyms and abbreviations	4
1.4	Compliance information	4
2	Safety Information	5
2.1	Definitions of signal warnings and warning symbols	5
2.2	Product specific safety notes	5
3	Design and Function	7
3.1	Overview	7
3.1.1	Overview balance	7
3.1.2	Overview type plate	8
3.1.3	Operation keys	8
3.1.4	Display	10
3.2	Basic principles for operation	11
4	Installation and Putting into Operation	14
4.1	Selecting the location	14
4.2	Scope of delivery	14
4.3	Unpacking	14
4.4	Installing components	15
4.5	Installing protective cover	17
4.6	Connecting the balance	18
4.7	Setting up the balance	19
4.7.1	Switching on the balance	19
4.7.2	Leveling the balance	19
4.7.3	Setting date and time	20
4.7.4	Adjusting the balance	21
4.8	Adjustment (calibration)	21
4.8.1	Adjustment with internal weight	21
4.8.2	Adjustment with external weight	22
4.8.3	Customer fine adjustment (model dependent)	22
4.9	Performing a simple weighing	24
4.10	Transporting the balance	26
4.10.1	Transporting over short distances	27
4.10.2	Transporting over long distances	27
4.10.3	Packaging and storage	27
4.11	Weighing below the balance	27
5	The Menu	29
5.1	What is in the menu ?	29
5.2	Description of menu topics	30
5.2.1	Main menu	30
5.2.2	Basic Menu	31
5.2.3	Advanced Menu	33
5.2.4	Interface Menu	35
6	Applications	39
6.1	Application piece counting	39
6.2	Application percent weighing	42
6.3	Application check weighing	44
6.4	Application statistics	46
6.5	Application formulation (Net total formulation)	48
6.6	Application totaling	51

6.7	Application dynamic weighing	53
6.8	Application multiplication factor weighing	55
6.9	Application division factor weighing	57
6.10	Application density	59
6.10.1	Density determination of solids	59
6.10.2	Density determination of liquids	61
6.10.3	Formulae used to calculate density	61
7	Communication with Peripheral Devices	64
7.1	PC-Direct function	64
7.2	Send weight value via RS232 to a PC using EasyDirect balance	66
8	Maintenance	68
8.1	Maintenance table	68
8.2	Performing routine tests	68
8.3	Cleaning	68
8.3.1	Cleaning agents	69
8.3.2	Cleaning the glass draft shield	69
8.3.3	Cleaning the balance	70
8.3.4	Putting into operation after cleaning	70
9	Troubleshooting	72
9.1	Error messages	72
9.2	Error symptoms	73
9.3	Status messages/Status icons	76
9.4	Putting into operation after fixing an error	76
10	Technical Data	77
10.1	General data	77
10.2	Model-specific data	78
10.2.1	Balances with readability of 0.01 mg with draft shield	78
10.2.2	Balances with readability of 0.1 mg with draft shield	79
10.2.3	Balances with readability of 1 mg with draft shield	82
10.2.4	Balances with readability of 10 mg / 100 mg	86
10.3	Dimensions	92
10.3.1	Balances with readability of 0.1 mg / 0.01 mg with draft shield high	92
10.3.2	Balances with readability of 1 mg with draft shield low	93
10.3.3	Balances with readability of 10 mg / 100 mg	94
10.4	Interface specification	95
10.4.1	RS232C interface	95
10.4.2	MT-SICS interface commands and functions	95
11	Accessories and Spare Parts	96
11.1	Accessories	96
11.2	Spare parts	101
12	Disposal	104
	Index	105

1 Introduction

Thank you for choosing a METTLER TOLEDO balance. The balance combines high performance with ease of use.

This document is based on the software version V 1.20.

EULA

The software in this product is licensed under the METTLER TOLEDO End User License Agreement (EULA) for Software.

▶ www.mt.com/EULA

When using this product you agree to the terms of the EULA.

1.1 Further documents and information

▶ www.mt.com/me-analytical

▶ www.mt.com/me-precision

This document is available in other languages online.

▶ www.mt.com/me-RM

Search for software downloads

▶ www.mt.com/labweighing-software-download

Search for documents

▶ www.mt.com/library

For further questions, please contact your authorized METTLER TOLEDO dealer or service representative.

▶ www.mt.com/contact

1.2 Explanation of conventions and symbols used

Conventions and symbols

Key and/or button designations and display texts are shown in graphic or bold text, e.g., , DATE.

Note For useful information about the product.



Refers to an external document.



This symbol indicates press key briefly (less than 1.5 s).



This symbol indicates press and hold key down (longer than 1.5 s).



This symbol indicates a flashing display.

Elements of instructions

In this manual, step-by-step instructions are presented as follows. The action steps are numbered and can contain prerequisites, intermediate results and results, as shown in the example. Sequences with less than two steps are not numbered.

- Prerequisites that must be fulfilled before the individual steps can be executed.

1 Step 1

⇒ Intermediate result

2 Step 2

⇒ Result

1.3 Acronyms and abbreviations

Original term	Explanation
ASTM	American Society for Testing and Materials
EMC	Electromagnetic Compatibility
FCC	Federal Communications Commission
GWP	Good Weighing Practice
ID	Identification
LPS	Limited Power Source
MT-SICS	METTLER TOLEDO Standard Interface Command Set
OIML	Organisation Internationale de Métrologie Légale (International Organization of Legal Metrology)
RM	Reference Manual
SNR	Serial Number
SOP	Standard Operating Procedure
UM	User Manual
USB	Universal Serial Bus
USP	United States Pharmacopeia

1.4 Compliance information

National approval documents, e.g., the FCC Supplier Declaration of Conformity, are available online and/or included in the packaging.

► <http://www.mt.com/ComplianceSearch>

European Union

The instrument complies with the directives and standards listed on the EU Declaration of Conformity.

United States of America

This equipment has been tested and found to comply with the limits for a **Class A** digital device, pursuant to part 15 of the FCC Rules. These limits are designed to provide reasonable protection against harmful interference when the equipment is operated in a commercial environment. This equipment generates, uses, and can radiate radio frequency energy and, if not installed and used in accordance with the instruction manual, may cause harmful interference to radio communications. Operation of this equipment in a residential area is likely to cause harmful interference in which case the user will be required to correct the interference at his own expense.

Changes or modifications not expressly approved by the party responsible for compliance could void the user's authority to operate the equipment.

2 Safety Information

Two documents named "User Manual" and "Reference Manual" are available for this instrument.

- The User Manual is printed and delivered with the instrument.
- The electronic Reference Manual contains a full description of the instrument and its use.
- Keep both documents for future reference.
- Include both documents if you transfer the instrument to other parties.

Only use the instrument according to the User Manual and the Reference Manual. If you do not use the instrument according to these documents or if the instrument is modified, the safety of the instrument may be impaired and Mettler-Toledo GmbH assumes no liability.

2.1 Definitions of signal warnings and warning symbols

Safety notes contain important information on safety issues. Ignoring the safety notes may lead to personal injury, damage to the instrument, malfunctions and false results. Safety notes are marked with the following signal words and warning symbols:

Signal words

DANGER	A hazardous situation with high risk, resulting in death or severe injury if not avoided.
WARNING	A hazardous situation with medium risk, possibly resulting in death or severe injury if not avoided.
CAUTION	A hazardous situation with low risk, resulting in minor or moderate injury if not avoided.
NOTICE	A hazardous situation with low risk, resulting in damage to the instrument, other material damage, malfunctions and erroneous results, or loss of data.

Warning symbols



General hazard: read the User Manual or the Reference Manual for information about the hazards and the resulting measures.



Electrical shock



Notice

2.2 Product specific safety notes

Intended use

This instrument is designed to be used by trained staff. The instrument is intended for weighing purposes.

Any other type of use and operation beyond the limits of use stated by Mettler-Toledo GmbH without consent from Mettler-Toledo GmbH is considered as not intended.

Responsibilities of the instrument owner

The instrument owner is the person holding the legal title to the instrument and who uses the instrument or authorizes any person to use it, or the person who is deemed by law to be the operator of the instrument. The instrument owner is responsible for the safety of all users of the instrument and third parties.

Mettler-Toledo GmbH assumes that the instrument owner trains users to safely use the instrument in their workplace and deal with potential hazards. Mettler-Toledo GmbH assumes that the instrument owner provides the necessary protective gear.

Safety notes



WARNING

Death or serious injury due to electric shock

Contact with parts that carry a live current can lead to death or injury.

- 1 Only use the METTLER TOLEDO power cable and AC/DC adapter designed for your instrument.
- 2 Connect the power cable to a grounded power outlet.
- 3 Keep all electrical cables and connections away from liquids and moisture.
- 4 Check the cables and the power plug for damage and replace them if damaged.



NOTICE

Damage to the instrument or malfunction due to the use of unsuitable parts

- Only use parts from METTLER TOLEDO that are intended to be used with your instrument.



NOTICE

Damage to the instrument or software

In some countries, excessive mains voltage fluctuations and strong glitches may occur. This may affect the instrument functions or damage the software.

- Use a voltage regulator for stabilizing.

3 Design and Function

3.1 Overview

3.1.1 Overview balance

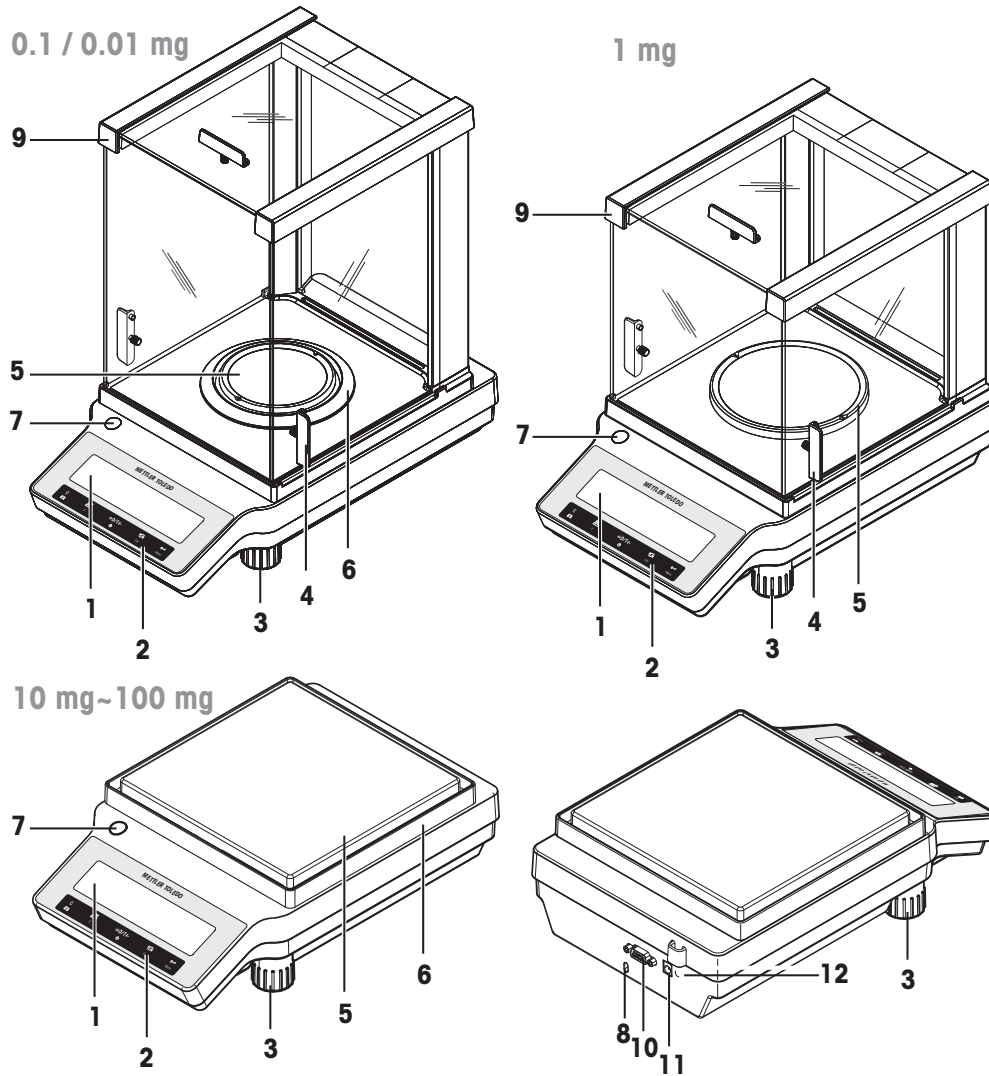

1	Display	2	Operation keys
3	Leveling foot	4	Handle for operation of the draft shield door
5	Weighing pan	6	Draft shield element
7	Level indicator	8	Kensington slot for anti-theft purposes
9	Glass draft shield	10	RS232C serial interface
11	Socket for AC adapter	12	Legal for Trade (LFT) sealing

3.1.2 Overview type plate

The balance type plate is located at the side of the balance and contains the following information (example illustration):

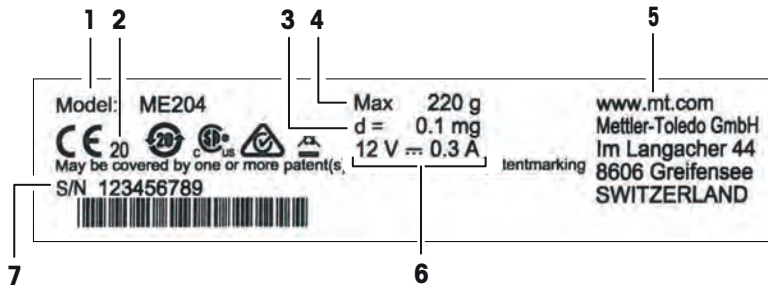



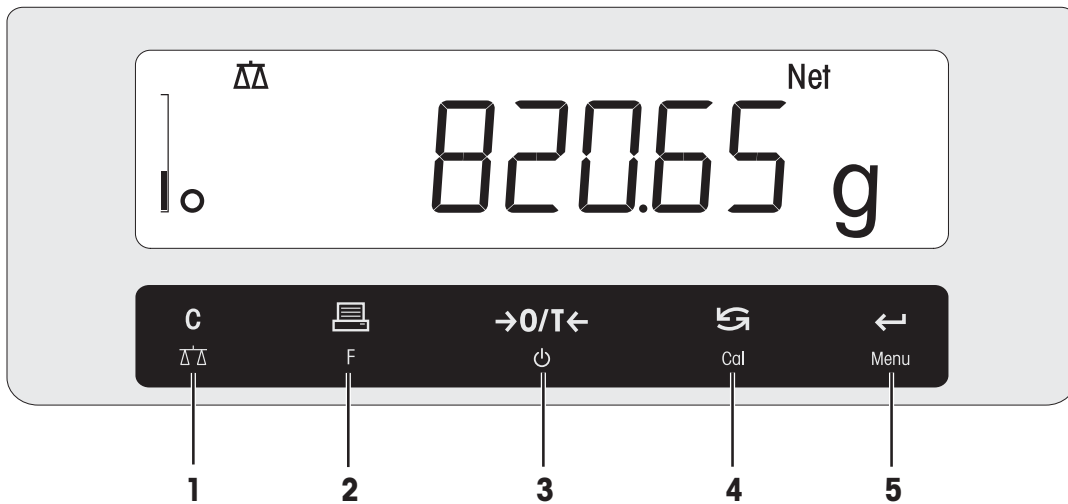

1	Model designation	2	Year of manufacture
3	Readability	4	Maximum capacity
5	Manufacturer	6	Power supply
7	Serial number (SNR)		

3.1.3 Operation keys



Legend key functions

No.	Key	Press briefly (less than 1.5 s)	Press and hold (longer than 1.5 s)
1	C ΔΔ	<ul style="list-style-type: none"> Cancel or leave menu without saving One step back in the menu 	<ul style="list-style-type: none"> Select the simple weighing application Exit application
2	 F	<ul style="list-style-type: none"> Print display value Transmit data To navigate backwards in the menu or menu selection Decrease parameters in menu or applications 	<ul style="list-style-type: none"> Open the application list for selecting an application
3	→0/T← ⏻	<ul style="list-style-type: none"> Zero/Tare Switch on 	<ul style="list-style-type: none"> Switch off into standby mode

No.	Key	Press briefly (less than 1.5 s) 	Press and hold (longer than 1.5 s) 
4	 Cal	<ul style="list-style-type: none"> • With entries, scroll down • To navigate forward menu topics or menu selections • To toggle between unit 1, recall value (if selected), unit 2 (if different from unit 1) and the application unit (if any) • Increase parameters in menu or applications. 	<ul style="list-style-type: none"> • Select adjustment (calibration) <ul style="list-style-type: none"> – with internal weight * – with external weight – Customer fine adjustment * <p>* On models with internal weight only</p>
5	 Menu	<ul style="list-style-type: none"> • Enter or leave menu selection • To enter application parameter digit and switch to next parameter digit • To accept parameter in menu selection. 	<ul style="list-style-type: none"> • Enter or leave menu (parameter settings) • To store parameter • To accept numeric inputs in applications.

3.1.4 Display

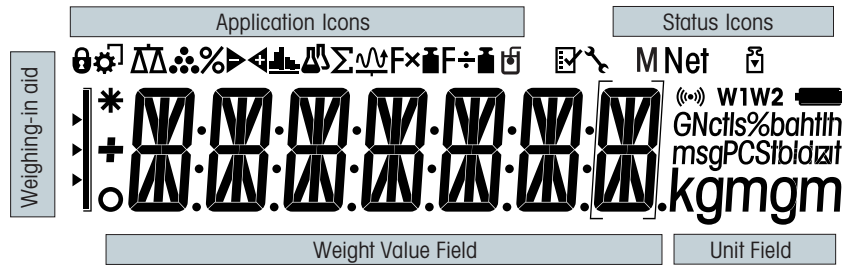

Application icons			
	Application weighing		Application totaling
	Application piece counting		Application dynamic weighing
	Application percent weighing		Application multiplication factor
	Application check weighing		Application division factor
	Application statistics		Application density
	Application formulation / Net total		Menu locked

While an application is running, the corresponding application icon appears at the top of the display.

Status icons			
M	Indicates stored value (Memory)		Feedback for pressed keys
Net	Indicates Net weight values	W1	Weighing range 1 (Dual Range models only)
	Adjustments (calibration) started	W2	Weighing range 2 (Dual Range models only)
	Service reminder		

Weight value field and weighing-in aid			
	Indicates negative values		Brackets to indicate uncertified digits (approved models only)
	Indicates unstable values		Marking of nominal or target weight
	Indicates calculated values		Marking of tolerance limit T+
			Marking of tolerance limit T-

Unit field						
GNctls%bahtlh msgPCStbdzjt kgmgm	g	gram	ozt	troy ounce	tls	Singapore taels
	kg	kilogram	GN	grain	tlt	Taiwan taels
	mg	milligram	dwt	pennyweight	tola	tola
	ct	carat	mom	momme	baht	baht
	lb	pound	msg	mesghal		
	oz	ounce	tlh	Hong Kong taels		

Note

The available units and the default unit are country specific.

3.2 Basic principles for operation

Selecting simple weighing or terminate application

- Press and hold $\Delta\Delta$ until **WEIGH** appears on the display.
- ⇒ The balance returns to the simple weighing mode.

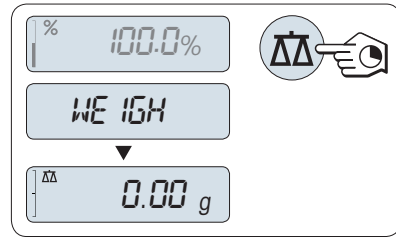

Note

How to perform simple weighing **see** [Performing a simple weighing ▶ Page 24].

Selecting an application

- 1 Press and hold **F** until **APP.LIST** (application list).
- ⇒ Last active application, e.g., **COUNT** appears on the display.
- 2 Select an application by multiple pressing ↻.
- 3 Press ↵ to execute selected application.

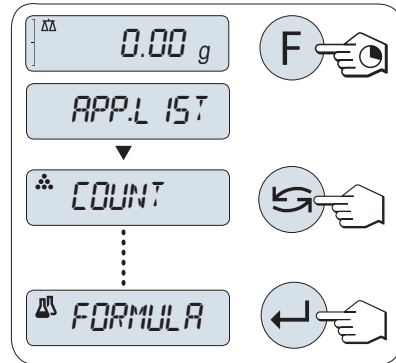

Available applications

Display	Remark	Description
COUNT	Piece counting	see [Application piece counting ▶ Page 39]
PERCENT	Percent weighing	see [Application percent weighing ▶ Page 42]
CHECK	Checkweighing	see [Application check weighing ▶ Page 44]
STAT	Statistics	see [Application statistics ▶ Page 46]
FORMULA	Formulation / Net-Total	see [Application formulation (Net total formulation) ▶ Page 48]
TOTAL	Totaling	see [Application totaling ▶ Page 51]
DYNAMIC	Dynamic weighing	see [Application dynamic weighing ▶ Page 53]
FACTOR.M	Multiplication factor	see [Application multiplication factor weighing ▶ Page 55]
FACTOR.D	Division factor	see [Application division factor weighing ▶ Page 57]
DENSITY	Density	see [Application density ▶ Page 59]

Entering the menu

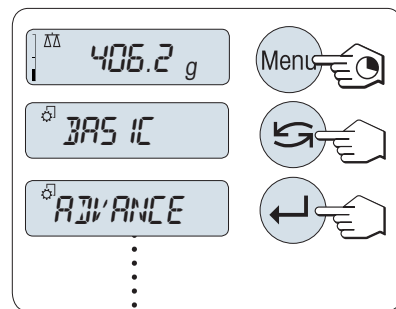

- 1 Press and hold **Menu** to enter main menu.
- ⇒ The first menu **BASIC** is displayed (except menu protection is active).
- 2 Press ↻ repeatedly to change menu.
- 3 Press ↵ to confirm the selection.



Note



Detailed description of the menu **see** [The Menu ▶ Page 29].

Selecting menu topics

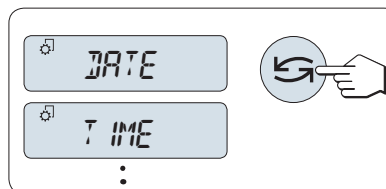
- 1 Press .
⇒ The next menu topic appears in the display.
- 2 Press  repeatedly, the balance switches to the next menu topic.



Changing settings in selected menu topic

- 1 Press .
⇒ The display shows the current setting in the selected menu topic.
- 2 Press  repeatedly, the balance switches to the next selection.
⇒ After the last selection, the first is shown again.
- 3 Press  to confirm the setting.

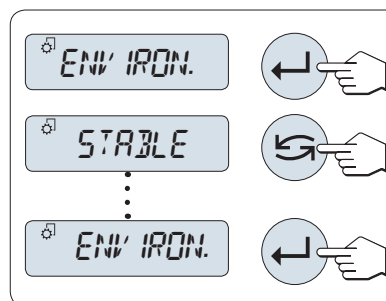

For store the setting see "Saving settings and closing the menu".



Changing settings in a submenu selection



The same procedure as for menu topics.

Input principle of numerical values

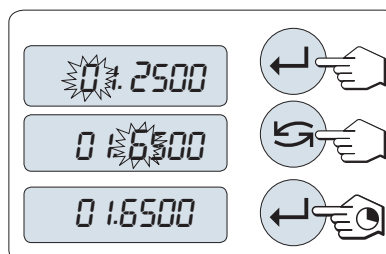
- 1 Press  to select a digit (cyclically from left to right) or a value (depending on the application).
⇒ The selected digit or the selected value is blinking.
- 2 Press  to increase or **F** to decrease for changing blinking digits or values.
- 3 Press and hold  to confirm the value.



Saving settings and closing the menu

- 1 Press and hold **Menu** to leave menu topic.
⇒ **SAVE:YES** appears on the display.
- 2 Press  to toggle between **SAVE:YES** and **SAVE:NO**.
- 3 Press  to execute **SAVE:YES**.
⇒ Changes are saved.
- 4 Press  to execute **SAVE:NO**.
⇒ Changes are not saved.

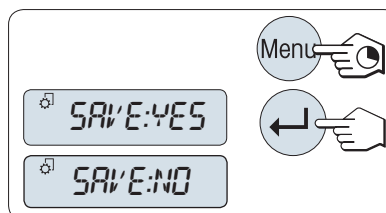

Cancel

- During menu operation
- 1 Press **C** for leaving menu topic or menu selection without saving (one step back in the menu).
 - 2 To leave menu topic or menu selection without saving press **C** (one step back in the menu).
- During application operation
 - Press **C** to cancel settings.

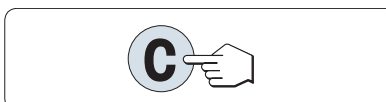

⇒ The balance returns to the previous active application.

Note

If no entry is made within 30 seconds, the balance reverts to last active application mode. Changes are not saved. If changes are made, the balance asks SAVE:NO.

4 Installation and Putting into Operation

4.1 Selecting the location

A balance is a sensitive precision instrument. The location where it is placed will have a profound effect on the accuracy of the weighing results.

Requirements of the location

Place indoors on stable table

Ensure sufficient spacing

Level the instrument

Provide adequate lighting



Avoid direct sunlight

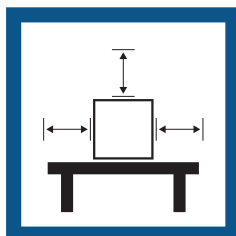

Avoid vibrations



Avoid strong drafts

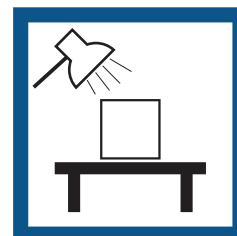

Avoid temperature fluctuations

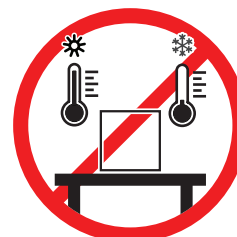
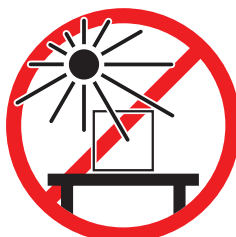

Sufficient spacing for balances: > 15 cm all around the instrument

Take into account the environmental conditions. See "Technical Data".

4.2 Scope of delivery

Components		0.01 mg	0.1 mg	1 mg	10 mg / 100 mg
Draft shield	high, 235 mm	✓	✓	–	–
	low, 170 mm	–	–	✓	–
Weighing pan with pan support	ø 80 mm	✓	–	–	–
	ø 90 mm	–	✓	–	–
	ø 120 mm	–	–	✓	–
	180 x 180 mm	–	–	–	✓
Draft shield element		✓	✓	–	✓
Pan support		–	–	–	✓
Protective cover		✓	✓	✓	✓
Universal AC/DC adapter		✓	✓	✓	✓
User Manual		✓	✓	✓	✓
Declaration of conformity		✓	✓	✓	✓

4.3 Unpacking

Open the balance packaging. Check the balance for transport damage. Immediately inform a METTLER TOLEDO representative in the event of complaints or missing accessories.

Retain all parts of the packaging. This packaging offers the best possible protection for transporting the balance.

4.4 Installing components



CAUTION

Injury due to breaking glass

Careless handling of the glass components can lead to breakage of glass and damage to cuttings.

- Always proceed focused and with care.

Balances with a readability of 0.1 / 0.01 mg with draft shield (235 mm)

Place the following components on the balance in the specified order:

- Push the side glass doors back as far as they will go.
- 1 Place draft shield element (1).
 - 2 Place weighing pan (2).

Further information for cleaning the draft shield, **see** chapter "Cleaning the glass draft shield".

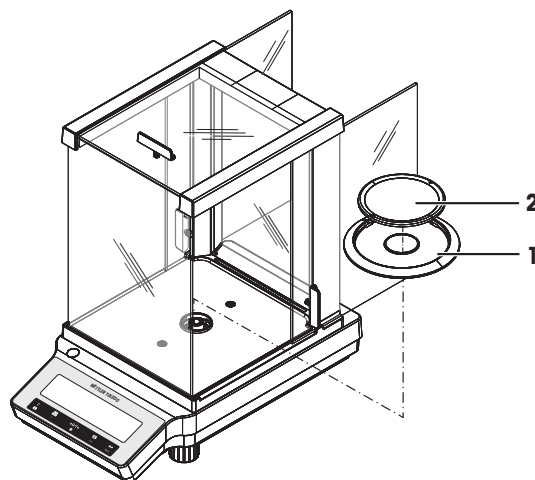

Balances with a readability of 1 mg with draft shield (170 mm)

Place the following components on the balance in the specified order:

- Push the side glass doors back as far as they will go.
- 1 Push the side glass doors back as far as will go.
 - 2 Place weighing pan (1).

Further information for cleaning the draft shield, **see** chapter "Cleaning the glass draft shield".

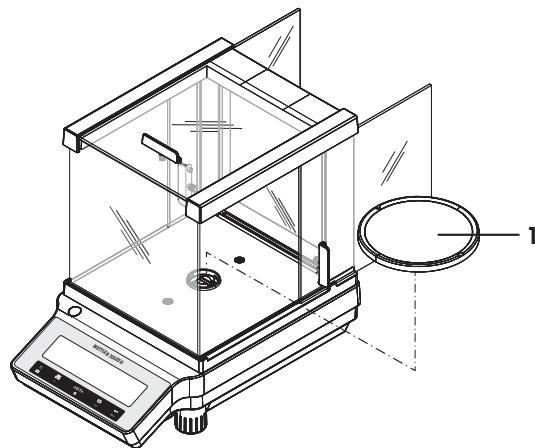

Balances with a readability of 10 mg / 100 mg

Place the following components on the balance in the specified order:

- 1 Place draft shield element (1): carefully pull apart the draft shield element to fix it under the retaining plate.
- 2 Insert pan support (2).
- 3 Place weighing pan (3).

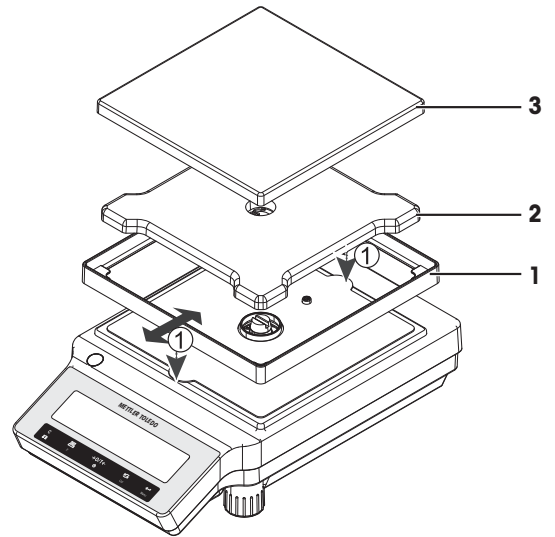

4.5 Installing protective cover



NOTICE

Damage to the instrument or malfunction due to the use of unsuitable parts

- Only use parts from METTLER TOLEDO that are intended to be used with your instrument.

Balances with readability of 0.01 mg / 0.1 mg / 1 mg

Install the protective cover according to the illustrations below, using a screwdriver.

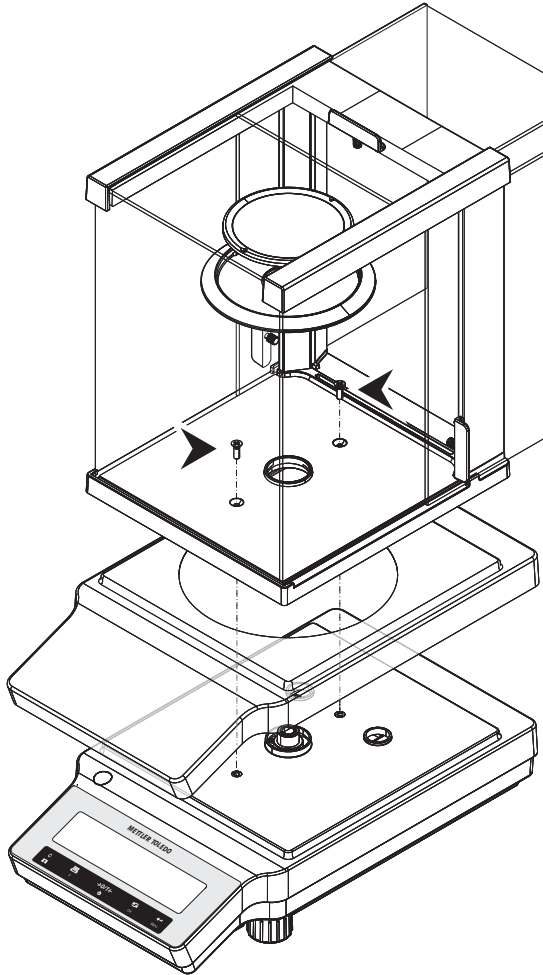

Balances with readability of 10 mg / 100 mg

Install the protective cover according to the illustrations below, using a screwdriver Torx TX20.

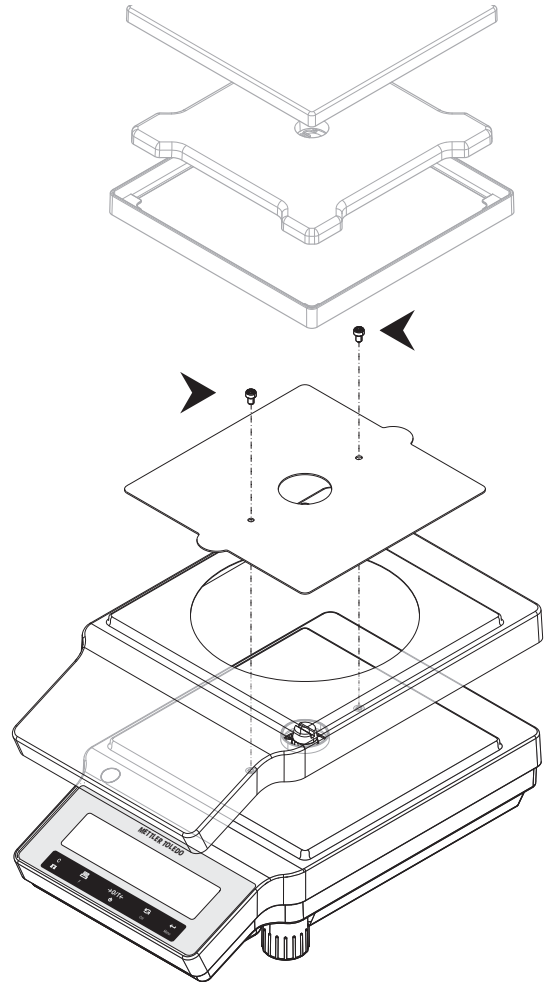

4.6 Connecting the balance



WARNING

Death or serious injury due to electric shock

Contact with parts that carry a live current can lead to death or injury.

- 1 Only use the METTLER TOLEDO power cable and AC/DC adapter designed for your instrument.
- 2 Connect the power cable to a grounded power outlet.
- 3 Keep all electrical cables and connections away from liquids and moisture.
- 4 Check the cables and the power plug for damage and replace them if damaged.



NOTICE

Damage to the AC/DC adapter due to overheating

If the AC/DC adapter is covered or in a container, it is not sufficiently cooled and will overheat.

- 1 Do not cover the AC/DC adapter.
- 2 Do not put the AC/DC adapter in a container.

- Install the cables so that they cannot be damaged or interfere with operation.
 - Insert the power cable in a grounded power outlet that is easily accessible.
- 1 Connect the AC/DC adapter (1) to the connection socket on the back of your balance.
 - 2 Connect the power cable (2) to the power socket.
 - ⇒ The balance performs a display test (all segments in the display light up briefly), **WELCOME**, **Software version**, **Maximum load** and **Readability** appears briefly.
 - ⇒ The balance is ready for use.

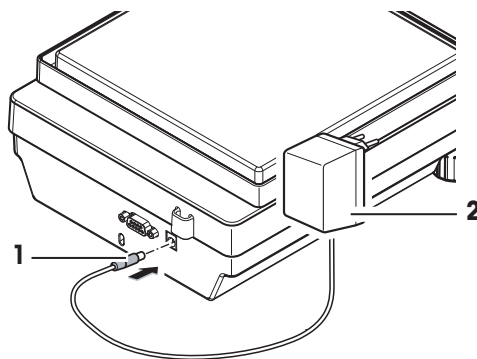

Note

Always connect the AC/DC adapter to the balance before connecting to the power.

Do not connect the instrument to a power outlet controlled by a switch. After switching on the instrument, it must warm up before giving accurate results.

4.7 Setting up the balance

4.7.1 Switching on the balance

Before using the balance, it must be warmed up in order to obtain accurate weighing results. To reach operating temperature, the balance must be connected to the power supply for at least 30 minutes (60 minutes for 0.1 mg / 0.01 mg models).

- The balance is connected to the power supply.
- The balance is in **STANDBY** mode. **MT.GREEN** appears on the display.
- Press .
- ⇒ The balance is ready for weighing or for operation with the last active application.

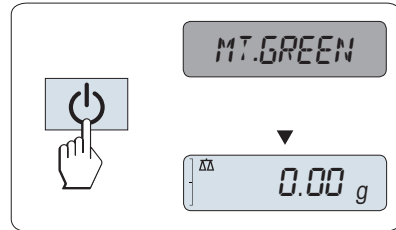

Legal-for-trade

Approved balances can only be switched on by pressing  in selected countries.

4.7.2 Leveling the balance

Exact horizontal and stable positioning are essential for repeatable and accurate weighing results. There are two adjustable leveling feet to compensate for slight irregularities in the surface of the weighing bench.

The balance must be leveled and adjusted each time it is moved to a new location.

- 1 Position the balance at the selected location.
- 2 Align the balance horizontally.
- 3 Turning the two front leveling feet of the housing until the air bubble is in the middle of the glass.

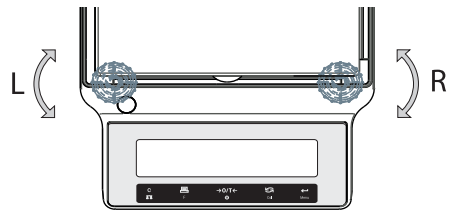

Example

Air bubble at 12 o'clock:



turn both feet clockwise.



Air bubble at 3 o'clock:



turn left foot clockwise, right foot counterclockwise.



Air bubble at 6 o'clock:



turn both feet counterclockwise.



Air bubble at 9 o'clock:



turn left foot counterclockwise, right foot clockwise.



4.7.3 Setting date and time

When you put your new instrument into operation for the first time, you should enter the current date and time.

Note

- These settings are retained even if you disconnect your instrument from the power supply.
- A reset of the instrument will not change these settings.
- Set the current date according to the date format DATE.FRM in the menu ADVANCE..
- Set the current time according to the time format TIME.FRM in the menu ADVANCE..

- 1 Press and hold **Menu** until menu **BASIC** appears on the display.
- 2 Press **←** to open menu **BASIC**.
⇒ **DATE** appears.
- 3 Press **←** to confirm.
- 4 **Set current date.** Press **←** to select day, month or year; press **↻** to set current day, month or year.
- 5 Press and hold **←** to confirm the settings.
⇒ **DATE** appears..
- 6 **Set current time.** Press **↻** to select **TIME**.
- 7 Press **←** to confirm.
⇒ **+1H** appears.
- 8 Select **SET.TIME** by pressing **↻**.
- 9 Press **←** to confirm.
- 10 Press **←** to select hours or minutes; press **↻** to set current hours or minutes.
- 11 Press and hold **←** to confirm the settings.
⇒ **TIME** appears.
- 12 Press and hold **←** to store the settings.
⇒ **SAVE:YES** appears.
- 13 Press **←** to confirm.

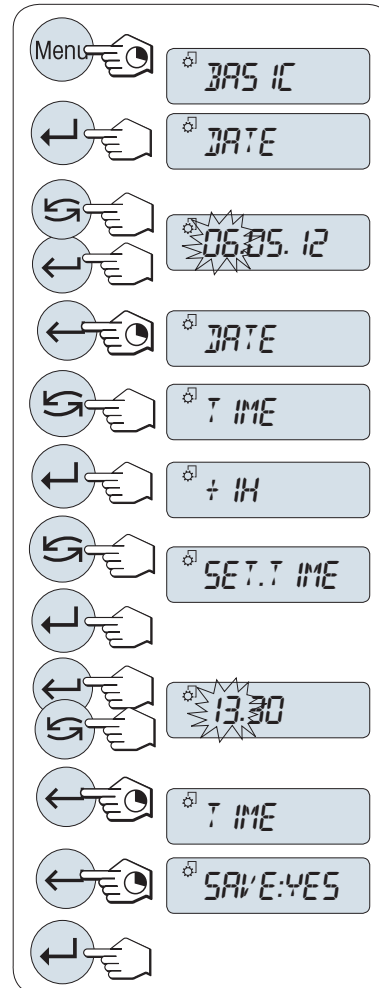

4.7.4 Adjusting the balance

To obtain accurate weighing results, the balance must be adjusted to match the gravitational acceleration at its location. This is also dependent on the ambient conditions. After reaching the operating temperature, it is important to adjust the balance in the following cases:

- Before the balance is used for the first time.
- If the balance has been disconnected from the power supply or in the event of power failure.
- After significant environmental changes, e.g., temperature, humidity, air draft or vibrations.
- At regular intervals during weighing service.

4.8 Adjustment (calibration)





NOTICE

Before adjusting the balance, it must be warmed up.

4.8.1 Adjustment with internal weight

Note

On models with internal weight only, see chapter "Technical Data".

- Weighing pan is unloaded.
- 1 Press and hold **CAL** until **ADJUST** appears.
 - 2 Select **ADJ.INT** by pressing .
⇒ **ADJ.INT** appears on the display.
 - 3 Press  to execute internal adjustment.
⇒ The adjusting is finished when the message **ADJ.DONE** appears briefly on the display. The balance returns to the last active application and is ready for operation.

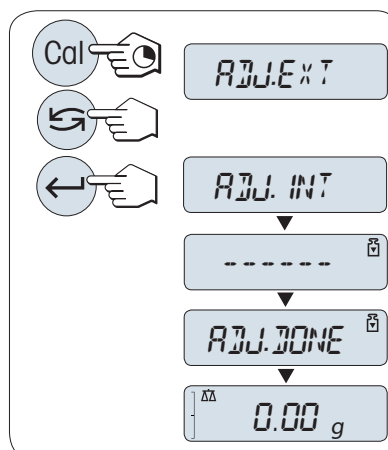





4.8.2 Adjustment with external weight

Note

Because of certification legislation, the approved models cannot be adjusted with an external weight * (depend on selected countries' certification legislation).

* except OIML accuracy class I approved models.

- Required adjustment weight is ready.
 - Weighing pan is unloaded.
- 1 Press and hold **CAL** until **ADJUST** appears.
 - 2 Select **ADJ.EXT** by pressing 
 - ⇒ **ADJ.EXT** appears on the display.
 - 3 Unload weighing pan.
 - 4 Optional: If necessary, you can define a different weight value. Press  to change a digit (cyclically from left to right); press  to change the blinking digit.
 - 5 Press and hold  to execute external adjustment.
 - ⇒ The required adjustment weight value flashes in the display.
 - 6 Place adjustment weight in center of pan.
 - ⇒ The balance adjusts itself automatically.
 - 7 When zero is flashing, remove adjustment weight.
 - ⇒ The adjusting is finished when the message **ADJ.DONE** appears briefly on the display. The balance returns to the last active application and is ready for operation.

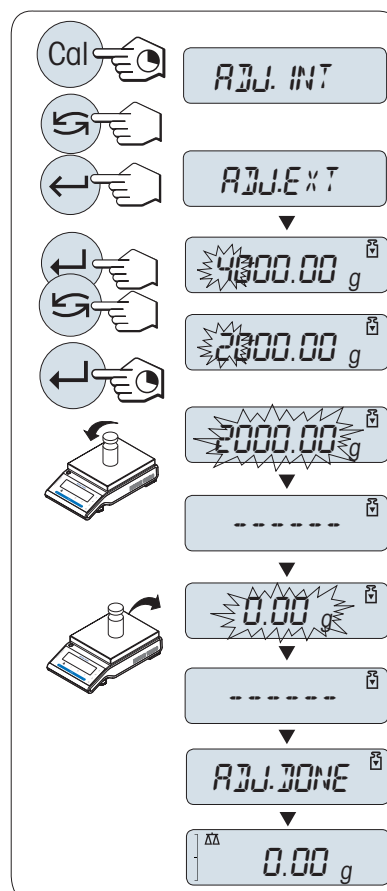

4.8.3 Customer fine adjustment (model dependent)



NOTICE

This function should be executed only by trained personnel.





The function customer fine adjustment ADJ.CF allows you to adjust the value of the internal adjustment weight with your own adjustment weight. The adjustable range of the adjustment weight is possible only in a very small range. Customer fine adjustment impacts the function of internal adjustment. The customer fine adjustment can be deactivated at any time.

Note

- This feature is available on models with internal weight only.
- Because of certification legislation, approved models cannot be adjusted with customer fine adjustment (depending on selected countries' certification legislation).
- Use certificated weights.

- Balance and test weight have to be on operating temperature.
- Observe the correct environmental conditions.

Execute customer fine adjustment

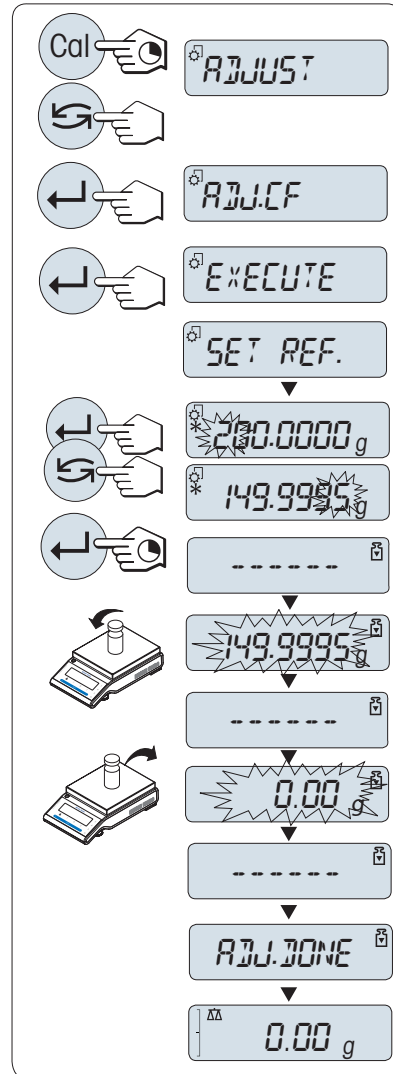

- The balance is under measuring condition.
 - Required adjustment weight is ready.
 - Weighing pan is unloaded.
- 1 Press and hold **CAL** until **ADJUST** appears.
 - 2 Select **ADJ.CF** by pressing .
 - ⇒ **ADJ.CF** appears on the display.
 - 3 Select **EXECUTE**.
 - 4 Start Adjustment with .
 - ⇒ **SET REF.** appears briefly.
 - ⇒ The last saved value flashes on the display.
 - 5 Select the target adjustment weight. Press  to change a digit (cyclically from left to right); press  to change the blinking digit.
 - 6 Press and hold  to confirm and execute **ADJ.CF**.
 - ⇒ The required adjustment weight value flashes in the display. This could take some time.
 - 7 Place required adjustment weight in center of pan.
 - 8 Remove adjustment weight when zero is flashing.
 - 9 Wait until **ADJ.DONE** briefly appears.
 - ⇒ The adjusting is finished when the message **ADJ.DONE** appears briefly on the display. The balance returns to the last active application and is ready for operation.
 - ⇒ If the error message **WRONG ADJUSTMENT WEIGHT** appears, the weight is not within the allowed value range and could not be accepted. **ADJ.CF** could not be executed.



Note

Storing the adjustment is not required.

Deactivate customer fine adjustment

- 1 Press and hold **CAL** until **ADJUST** appears.
- 2 Select **ADJ.CF** by pressing .
 - ⇒ **ADJ.CF** appears on the display.
- 3 Select **RESET**.
- 4 Start **RESET** by pressing .
 - ⇒ **NO?** appears.

5 Select **YES?** and confirm with \leftarrow .

⇒ The adjusting is finished when the message **ADJ.DONE** appears briefly on the display. The balance returns to the last active application and is ready for operation with initial adjustment.

4.9 Performing a simple weighing



The weighing application allows you to perform simple weighings and how you can accelerate the weighing process.

If your balance is not in the weighing mode, press and hold the $\Delta\Delta$ key down until **WEIGHING** appears in the display. Release the key. Your balance is in the weighing mode and set to zero.

- 1 Press $\rightarrow 0/T \leftarrow$ to zero the balance.
- 2 Place the sample on the weighing pan.
- 3 Wait until the instability detector \circ disappears.
- 4 Read the result.

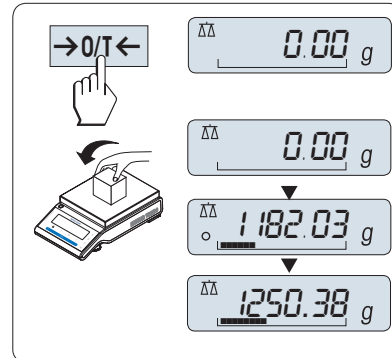

Zeroing

Use the $\rightarrow 0/T \leftarrow$ zeroing key before you start with a weighing.

- 1 Unload the balance.
- 2 Press $\rightarrow 0/T \leftarrow$ to set the balance to zero.
All weight values are measured in relation to this zero point.

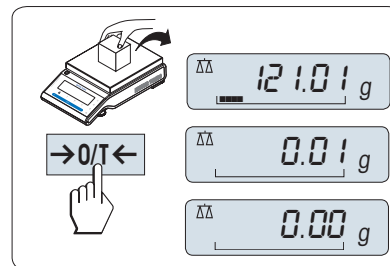

Taring

If you are working with a weighing container, first set the balance to zero.

- 1 Place empty container on the weighing pan.
 - ⇒ The weight is displayed.
- 2 Press **→0/T←** to set the balance to zero.
 - ⇒ **0.00 g** and **Net** appears in the display. **Net** indicates that all weight values displayed are net values.
- 3 Place weighing sample into the weighing container.
 - ⇒ The result appears in the display.
 - If the container is removed from the balance, the tare weight will be shown as a negative value.
 - The tare weight remains stored until the **→0/T←** key is pressed again or the balance is switched off.

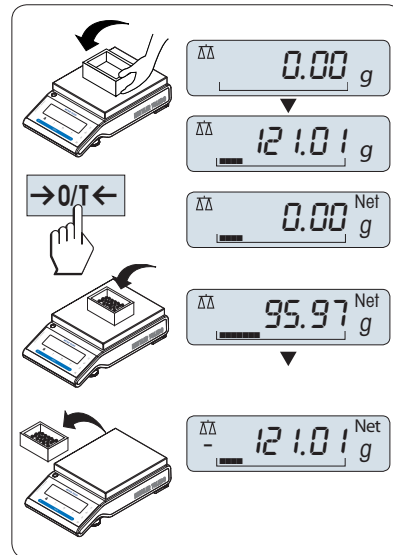

Switching weight units

The **↻** key can be used at any time to toggle between weight unit UNIT 1, RECALL value (if selected) and weight unit UNIT 2 (if different from weight unit 1) and the application unit (if any).

- Press **↻** to set weight unit or recall value.

Recall / recall weight value

Recall stores stable weights with an absolute display value bigger than 10d.

- Function **RECALL** is in the menu activated.

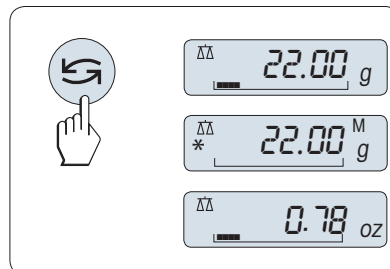

- 1 Load weighing sample.
 - ⇒ The display shows weight value and stores stable value.
- 2 Remove weighing sample.
 - ⇒ The display shows zero.
- 3 Press **↻**.
 - ⇒ The display shows last stored stable weight value for 5 seconds together with asterisk (*) and memory (M) symbols. After 5 seconds the display goes back to zero. This can be repeated unlimited times.

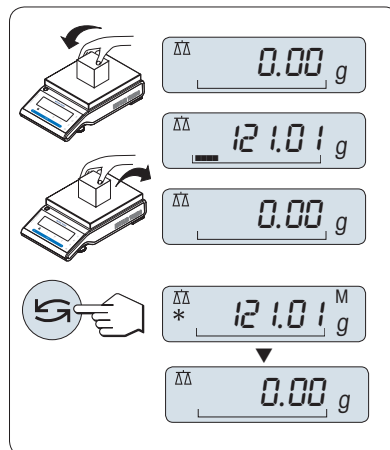

Delete last weight value

As soon a new stable weight value is displayed, the old recall value becomes replaced by the new weight value.

- Press **→0/T←**.
 - ⇒ The recall value is set to 0.

If the power is switched off, the recall value is lost. The recall value can not be printed.

Weighing with the weighing-in aid

The weighing-in aid is a dynamic graphic indicator which shows the used amount of the total weighing range. You can thus recognize at a glance when the load on the balance approaches the maximum load.

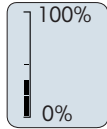

Print / transmit data

Press the  key to transmit the weighing results over the interface, e.g., to a printer or a PC.

Switching off

- Press and hold the  key until **STANDBY** appears on the display. Release the key.
- ⇒ **MT.GREEN** appears on the display.
- After switching on from standby mode, your balance needs no warm-up time and is immediately ready for weighing.
- To completely switch off the balance, disconnect it from the power supply.

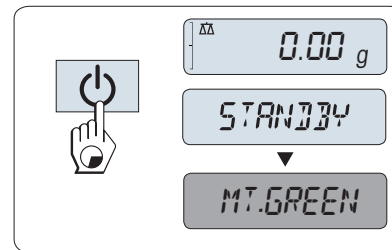

Legal-for-trade

Standby mode is not possible with approved balances (only available in selected countries).

4.10 Transporting the balance



CAUTION

Injury due to breaking glass

Careless handling with the glass components can lead to breakage of glass and damage to cuttings.

- 1 Do not lift the instrument by the glass draft shield.
- 2 Always proceed focused and with care.

- 1 Press and hold the  key.
- 2 Disconnect the balance from the power supply.
- 3 Disconnect all interface cables.

4.10.1 Transporting over short distances

To move the balance over a short distance to a new location, follow the instructions below.

- 1 Hold the balance with both hands as shown.
- 2 Carefully lift the balance and carry it to its new location.

If you want the balance put into operation, proceed as follows:

- 1 Connect in reverse order.
- 2 Level the balance.
- 3 Perform an internal adjustment.

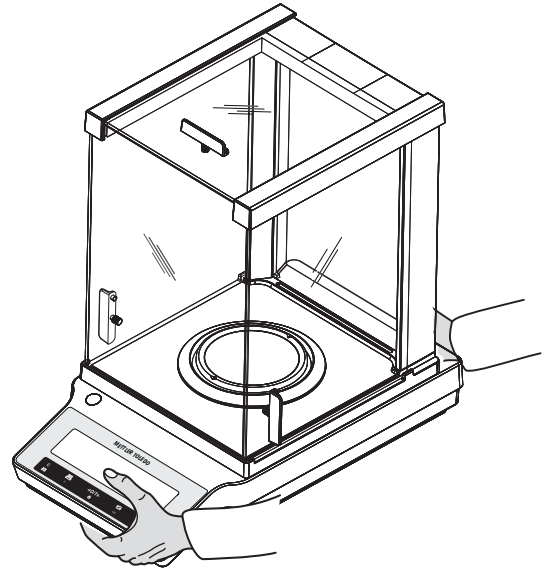

4.10.2 Transporting over long distances

To transport the balance over long distances, always use the original packaging.

4.10.3 Packaging and storage

Packaging

Store all parts of packaging in a safe place. The elements of the original packaging are developed specifically for the balance and its components to ensure maximum protection during transportation or storing.

Storage

Store the balance under following conditions:

- Indoor and in the original packaging.
- According to the environmental condition, see "Technical data".
- When storing for longer than two days, the backup battery may be down (date and time get lost).

4.11 Weighing below the balance

Your balance is equipped with a weighing hook for performing weighing operations below the work surface (weighing below the balance).



NOTICE

Damage to balance

Do not place the balance on the pan support location bolt.

- 1 Press and hold the  key.
- 2 Disconnect the balance from the power supply.
- 3 Disconnect all interface cables.

- 1 Remove weighing pan, pan support and EMC plate if present.
- 2 Turn the balance carefully on its side.
- 3 Remove the cap (keep it for later use). The hanger is now accessible.
- 4 Turn the balance to its normal position and simply reinstall all components in the reverse order.

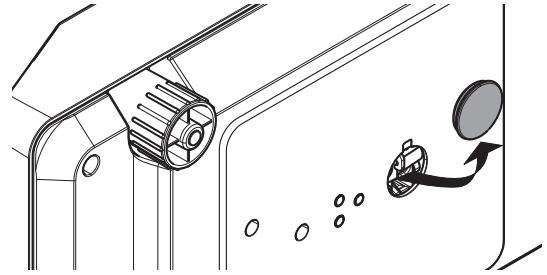

5 The Menu

5.1 What is in the menu ?

The menu allows you to match your balance to your specific weighing needs. In the menu you can change the settings of your balance and activate functions. The main menu has 4 different menus and these contains different topics, each of which allows you various selection possibilities.

For menu PROTECT **see** [Main menu ▶ Page 30].

Menu BASIC

Topic	Explanation	Description
DATE	Setting the current date.	[see ▶ Page 31]
TIME	Setting the current time.	[see ▶ Page 31]
1/10 D	Setting display increment (1/10d function)	[see ▶ Page 31]
UNIT 1	Specification of the 1 st weight unit in which the balance should show the result.	[see ▶ Page 31]
UNIT 2	Specification of the 2 nd weight unit in which the balance should show the result.	[see ▶ Page 31]
SET ID	Setting an identification.	[see ▶ Page 32]
PRT.MENU	Printing the settings.	[see ▶ Page 32]
RESET	Call up of the factory settings.	[see ▶ Page 31]

Menu ADVANCE.

Topic	Explanation	Description
ENVIRON.	Matching the balance to the ambient conditions.	[see ▶ Page 33]
ADJ.LOCK	Switching the adjustment function on or off.	[see ▶ Page 33]
DATE.FRM	Setting the date format.	[see ▶ Page 33]
TIME.FRM	Preselection of the time format.	[see ▶ Page 33]
RECALL	Switching the application recall for storing stable weights on or off.	[see ▶ Page 33]
STANDBY	Setting the time after which the balance should be switched off automatically.	[see ▶ Page 34]
B.LIGHT	Switching on or off the display backlight.	[see ▶ Page 34]
A.ZERO	Switching the automatic zero correction (Autozero) on or off.	[see ▶ Page 34]
ZERO.RNG	Setting the zero limit of the zero/tare key.	[see ▶ Page 34]
SRV.ICON	Switching the service reminder (service icon) on or off.	[see ▶ Page 34]
SRV.D.RST	Reset service date and hours (service reminder).	[see ▶ Page 34]

Menu INT.FACE

Topic	Explanation	Description
RS232	Matching the serial interface RS232C to a peripheral unit.	[see ▶ Page 35]
HEADER	Setting the header for printout of individual values.	[see ▶ Page 35]
SINGLE	Setting the information for printout of individual values.	[see ▶ Page 36]
SIGN.L	Setting the footer for printout of individual values.	[see ▶ Page 36]
LN.FEED	Setting line feed for printout of individual values.	[see ▶ Page 36]
ZERO.PRT	Setting the auto print function for printing zero.	[see ▶ Page 36]
COM.SET	Setting the data communication format of the serial interface RS232C.	[see ▶ Page 36]
BAUD	Setting the transfer speed of the serial interface RS232C.	[see ▶ Page 37]
BIT.PAR.	Setting the character format (Bit/Parity) of the serial interface RS232C.	[see ▶ Page 37]
STOPBIT	Setting the character format (stop bit) of the serial interface RS232C.	[see ▶ Page 38]
HD.SHK	Setting the transfer protocol (Handshake) of the serial interface RS232C.	[see ▶ Page 38]
RS.TX.E.O.L.	Setting the end of line format of the serial interface RS232C.	[see ▶ Page 38]
RS.CHAR	Setting the char set of the serial interface RS232C.	[see ▶ Page 38]
INTERVL.	Selection of the time interval for the simulated print key press.	[see ▶ Page 38]

5.2 Description of menu topics

In this section you will find information regarding the individual menu topics and the available selections.

5.2.1 Main menu

Selecting the submenu.

BASIC	The small BASIC menu for simple weighing is displayed.
ADVANCE.	The extended ADVANCE. menu for further weighing settings is displayed.
INT.FACE	The menu INT.FACE for all interface parameter settings for peripheral devices e.g. printer is displayed.
PROTECT	Menu protection. Protection of balance configurations against unmeant manipulation.
OFF	Menu protection is off. (Factory setting)
ON	Menu protection is on. The menu BASIC, ADVANCE. and INT.FACE are not displayed. This is indicated with  in the display.

5.2.2 Basic Menu

DATE – Date

Setting the current date according to date format.

Note

A reset of the balance will not change this setting.

TIME – Time

Setting the current time according to time format

+1H	Set the current time forwards by 1 hour (to adjust summer or winter time). (Factory setting)
-1H	Set the current time backwards by 1 hour (to adjust summer or winter time).
SET TIME	Enter the current time.

Note

A reset of the balance will not change this setting.

1/10 D – Display increment 1/10 d

This menu topic allows you to reduce the readability of the display.

Legal-for-trade

This menu topic is not available with models which are approved and e=d.

OFF	1/10 D display increment is switched off (full resolution) (Factory setting)
ON	1/10 D switched on (low resolution)

Note

A reset of the balance will not change this setting.

UNIT 1 – Weight unit 1

Depending on requirements, the balance can operate with the following units (country and model specific).

Legal-for-trade

- Only those weight units allowed by the appropriate national legislation are selectable.
- With approved balances, this menu topic has a fixed setting and cannot be changed.

Units:

g	Gram	dwt	Pennyweight
kg	Kilogram	mom	Momme
mg	Milligram	msg	Mesghal
ct	Carat	tlh	Tael Hong Kong
lb	Pound	tls	Tael Singapore
oz	Ounce (avdp)	tlt	Tael Taiwan
ozt	Ounce (troy)	tola	Tola
GN	Grain	baht	Baht

UNIT 2 – Weight unit 2

If it is required to show the weighing results in weighing mode in an additional unit, the desired second weight unit can be selected in this menu topic (country and model specific). Units see UNIT 1.

Legal-for-trade

Only those weight units allowed by the appropriate national legislation are selectable.



SET ID – Set identification

This menu topic allows you to set your own desired identification to the balance for the convenience of asset management or other purposes. The ID can be printed with other balance information. One ID can be set and max 7 alphanumeric characters are possible (blank, 0...9, A...Z).

SET ID

Set identification

The setting starts from left to right and the display prompts the configurable position by flashing corresponding place.

- **SET ID** is selected.
- 1 Search through (blank, 0...9, A...Z) by pressing .
- 2 After selecting the character, press  to confirm and move to the next place. To store press and hold .

Note

A reset of the balance will not change this setting.

PRT.MENU – Print menu

This menu topic allows you to execute a printout of the menu settings if a printer is connected. This topic is only visible if PRINTER mode is selected.

- **PRT.MENU** appears on the display and a printer is properly connected.
- To execute a printout press .

RESET – Reset balance settings

This menu topic allows you to call-up the factory settings.

To toggle between YES? and NO? press .

Note

A reset of the balance will not change DATE, TIME, **1/10 D**, SET ID and ZERO.RNG settings.

5.2.3 Advanced Menu

ENVIRON. – Environment settings

This setting can be used to match your balance to the ambient conditions.

STD.	Setting for an average working environment subject to moderate variations in the ambient conditions. (Factory setting)
UNSTAB.	Setting for a working environment where the conditions are continuously changing.
STABLE	Setting for a working environment which is practically free from drafts and vibrations.

ADJ.LOCK – Adjustment (calibration) lock

Under this menu topic you can lock function of the CAL key.

OFF	The adjustment lock is switched off . The adjustment function is on. The CAL key is active. (Factory setting)
ON	The adjustment lock is switched on . The adjustment function is off. The CAL key has no function.

DATE.FRM – Date format

This menu topic allows you to preselect the date format.

The following date formats are available:

	Display examples	Printing examples
DD.MM.Y	01.02.09	01.02.2009
MM/DD/Y	02/01/09	02/01/2009
Y-MM-DD	09-02-01	2009-02-01
D.MMM Y	1.FEB.09	1.FEB 2009
MMM D Y	FEB.1.09	FEB 1 2009

Factory setting: DD.MM.Y

TIME.FRM – Time format

This menu topic allows you to preselect the time format.

The following date formats are available:

	Display examples
24:MM	15:04
12:MM	3:04 PM
24.MM	15.04
12.MM	3.04 PM

Factory setting: 24:MM

RECALL – Recall

This menu topic allows you to switch the RECALL function on or off. When it is switched on recall stores the last stable weight if the absolute display value was bigger than 10d.

OFF	RECALL switched off . (Factory setting)
ON	RECALL switched on .

The recall value is displayed with an asterisk and cannot be printed.

STANDBY – Automatic standby

If the automatic standby function is activated, the balance automatically switches itself after a pre selected time of inactivity into the energy saver mode STANDBY (e.g., with no key being pressed and no changes of weight occurring).

A.OFF	Automatic standby deactivated.
A.ON	Automatic standby activated (Factory setting).
60	Time in minutes of inactivity for activating standby function. Setting range: 2...720 minutes.

B.LIGHT – Backlight

Under this menu topic, the display backlight can be switched off or on.

B.L. ON	Backlight is always on . (Factory setting)
B.L. OFF	Backlight is always off .

A.ZERO – Automatic zero setting

This menu topic allows you to switch the automatic zero setting on or off.

ON	A.ZERO switched on (Factory setting). The automatic zero setting continuously corrects possible variations in the zero point that might be caused through small amounts of contamination on the weighing pan.
OFF	A.ZERO switched off . The zero point is not automatically corrected. This setting is advantageous for special applications, e.g., evaporation measurements.

Legal-for-trade

With approved balances, this setting is not available in selected countries.

– Zero rangeZERO.RNG

This menu topic allows you to set a zero limit for the $\rightarrow 0/T \leftarrow$ key. Up to and including this limit the $\rightarrow 0/T \leftarrow$ key will execute a zero. Above this limit the $\rightarrow 0/T \leftarrow$ key will execute a tare.

21 g	To set the upper limit of the zeroing range as weight in the definition unit of the balance. Factory setting: 0.5% of weighing range.
-------------	----------------------------------------------------------------------------------------------------------------------------------------------

Legal-for-trade



With approved balances, this setting is not available and fixed to 3e (only available in selected countries).

Note

A reset of the balance will not change this setting.

SRV.ICON – Service reminder

This menu topic allows you to switch the service reminder  on or off.

ON	Service reminder  switched on . You will be informed to call service for recalibration. This will be indicated by the flashing service icon:  . (Factory setting)
OFF	Service reminder  switched off .

SRV.D.RST – Service date reset

This menu topic allows you to reset service date.

Note











This menu topic is only available if SRV.ICON setting ON was selected.

To toggle between YES? and NO? press .

5.2.4 Interface Menu

RS232 – RS232C interface

At this menu topic you can select the peripheral device connected to the RS232C interface and specify how the data is transmitted.

PRINTER	Connection to a printer. (Factory setting) Only one printer possible.  Refer to your printer documentation for recommended printer settings.
PRT.STAB	If the  key is pressed, the next stable weight value will be printed. (Factory setting)
PRT.AUTO	Every stable weight value will be printed, without pressing the  key.
PRT.ALL	If the  key is pressed, the weight value will be printed regardless of stability.
PC-DIR.	Connection to a PC: the balance can send data (as a Keyboard) to the PC used for PC applications, e.g., Excel. <ul style="list-style-type: none">• The balance sends the weight value without the unit to the PC.• Not available on Win7.
PRT.STAB	If the  key is pressed, the next stable weight value will be sent followed by an enter. (Factory setting)
PRT.AUTO	Every stable weight value will be sent followed by an enter, without pressing the  key.
PRT.ALL	If the  key is pressed, the weight value will be sent followed by an enter regardless of stability.
HOST	Connection to a PC, barcode reader etc.: the balance can send data to the PC and receive commands or data from the PC. The balance sends the complete MT-SICS answer to the PC, see chapter "MT-SICS interface commands and functions".
SND.OFF	Send mode switched off. (Factory setting)
SND.STB	If the  key is pressed, the next stable weight value will be sent.
SND.CONT	All weight value updates will be sent regardless of stability, without pressing the  key.
SND.AUTO	Every stable weight value will be sent, without pressing the  key.
SND.ALL	If the  key is pressed, the weight value will be sent regardless of stability.
2.DISP	Connection of an optional auxiliary display unit. The transmission parameters cannot be selected. Settings are automatically set.

HEADER – Options for the printout header of individual values

This menu topic allows you to specify the information that is to be printed at the top of the printout for every individual weighing results (after pressing .

Note

This menu topic is only available if PRINTER setting was selected.

NO	The header is not be printed. (Factory setting)
----	--------------------------------------------------------

DAT/TIM	Date and time are printed.
D/T/BAL	Date, time and balance information (Balance type, SNR, Balance ID) are printed.
	Balance ID only if set.

SINGLE – Options for printing out the result of individual values

This menu topic allows you to specify the information that is to be printed for every individual weighing result (after pressing .

Note

This menu topic is only available if PRINTER setting was selected.

NET	The value of the net weight from the current weighing is printed. (Factory setting)
G/T/N	The values of the gross weight, the tare weight and the net weight are printed.

SIGN.L – Options for the printout footer for signature line of individual values

This menu topic allows you to set a footer for signature at the bottom of the printout for every individual weighing result (after pressing .

Note

This menu topic is only available if PRINTER setting was selected.

OFF	The signature footer is not be printed. (Factory setting)
ON	The signature footer is printed.

LN.FEED – Options for complete the printout of individual values

This menu topic allows you to specify the number of blank lines to complete the printout (line feed) for every individual weighing result (after pressing .

Note

This menu topic is only available if PRINTER setting was selected.

0	Possible numbers of blank lines: 0 to 99. (Factory setting = 0)
----------	------------------------------------------------------------------------

ZERO.PRT – Options for PRT.AUTO

This menu topic allows you to specify the auto print function PRT.AUTO for printing zero YES or NO.

OFF	Zero is not be printed (Zero +/- 3d). (Factory setting)
ON	Zero is always printed.

Note

This menu topic is only available if PRT.AUTO function of the PRINTER or PC-DIR. was selected.

COM.SET – Options for the data communication format (RS232C) (HOST)

This menu topic allows you to set the data format depending on which peripheral device is connected.

Note

This menu topic is only available if HOST setting was selected.

MT-SICS	The MT-SICS data transfer formats is used. (Factory setting) For more information, see "MT-SICS interface commands and functions".
SART	The following Sartorius commands are supported: K Ambient conditions: very stable L Ambient conditions: stable M Ambient conditions: unstable

N	Ambient conditions: very unstable
O	Block keys
P	Print key (print, auto print; activate or block)
R	Unblock keys
S	Restart/self-test
T	Tare key
W	Calibration/adjustment *)
Z	Internal calibration/adjustment **)
f1_	Function key (CAL)
s3_	C key
x0_	Perform internal calibration **)
x1_	Print balance/scale model
x2_	Print weighing cell serial number
x3_	Print software version

*) May be inaccessible on verified balances/scales

***) Only on models with built-in motorized calibration weight

Functionality mapping

HOST settings:	Sartorius printer settings:
SND.OFF	not applicable
SND.STB	manually print with stability
SND.ALL	manually print without stability
SND.CONT	automatically print without stability
SND.AUTO	similar applicable to automatically print when load is changed

BAUD – Baud rate RS232C

This menu topic allows you to match the data transmission to different serial RS232C receivers. The baud rate (data transfer rate) determines the speed of transmission via the serial interface. For problem-free data transmission the sending and receiving devices must be set at the same value.

The following settings are available:

600 bd, 1200 bd, 2400 bd, 4800 bd, **9600 bd (Factory setting)**, 19200 and 38400 bd.

Note

- Not visible for 2nd display.
- Each device has separate settings.

BIT.PAR. – Bit/Parity RS232C

At this menu topic you can set the character format for the attached RS232C serial peripheral device.

8/NO	8 data bits/no parity (Factory setting)
7/NO	7 data bits/no parity
7/MARK	7 data bits/mark parity
7/SPACE	7 data bits/space parity
7/EVEN	7 data bits/even parity
7/ODD	7 data bits/odd parity

Note

- Not visible for 2nd display.
- Each device has separate settings.

STOPBIT – Stop bits RS232C

At this menu topic you can set the stop bits of the transmitted data to different RS232C serial receivers.

1 BIT	1 Stop bit (Factory setting)
2 BITS	2 Stop bits

HD.SHK – Handshake RS232C

This menu topic allows you to match the data transmission to different RS232C serial receivers.

XON.XOFF	Software handshake (XON/XOFF) (Factory setting)
RTS.CTS	Hardware handshake (RTS/CTS)
OFF	No handshake

Note

- Not visible for 2nd display.
- Each device has separate settings.

RS.TX.E.O.L. – End of line RS232C

At this menu topic you can set the end of line character of the outgoing transmitted data to different RS232C serial receivers.

CR LF	Carriage Return followed by Line feed (ASCII-Codes 013 + 010) (Factory setting)
CR	Carriage Return (ASCII-Code 013)
LF	Line feed (ASCII-Code 010)
TAB	Horizontal tab (ASCII-Code 009) (only visible if PC-DIR. is selected)

Note

- Not visible for 2nd display.
- Each device has separate settings.

RS.CHAR – Char set RS232C

At this menu topic you can set the character set of the transmitted data to different RS232C serial receivers.

IBM.DOS	Char set IBM/DOS (Factory setting)
ANSI.WIN	Char set ANSI/WINDOWS

Note

- Not visible for 2nd display.
- Each device has separate settings.

INTERVL. – Print key simulation

At this menu topic you can activate a simulation of the  key. INTERVL. simulates a print key press every x seconds.

Range:	0 to 65535 seconds
0 sec:	Disables the print key simulation

Factory setting: 0 sec



The executed action is according to the configuration of the print key, see interface setting.

6 Applications

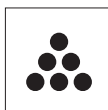
6.1 Application piece counting



The **Piece counting** application allows you to determine the number of pieces put on the weighing pan.

- 1 Press and hold **F** to call-up **APP.LIST**.
- 2 Select application **COUNT** by scrolling with .
- 3 Press  to activate the function.

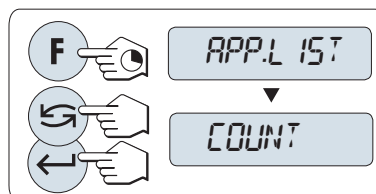





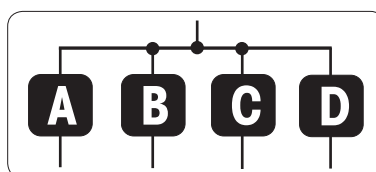

Piece counting first requires the setting of a reference weight, there are 4 possibilities

- **A** Setting the reference **by multiple pieces with fix reference values**.
- **B** Setting the reference **by multiple pieces with variable reference values**.
- **C** Setting the reference **for 1 piece in weighing mode**.
- **D** Setting the reference **for 1 piece in manual mode**.



Setting the reference by multiple pieces with fix reference values

- 1 Select a number of reference pieces by scrolling with . Possible numbers* are 5, 10, 20 and 50.
- 2 Press  **0/T**  to zero the balance. If using: place empty container on the weighing pan and press  **0/T**  to tare the balance.
- 3 Add the selected number of reference pieces to container.
- 4 Press  to confirm.

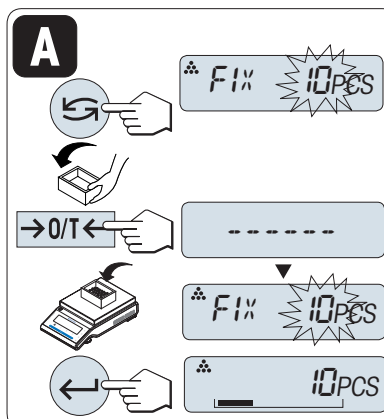

Legal-for-trade

* with approved balances in selected countries: min 10.

Setting the reference by multiple pieces with variable reference values

- 1 Select **VAR.REF** by scrolling with ↻.
- 2 Press ↵ to confirm.
- 3 Select the number of reference pieces. Possible numbers* are 1 to 999.
- 4 Press ← to select a digit (cyclically from left to right).
⇒ The selected digit is blinking.
- 5 Press ↻ to change the digit.
- 6 Press →0/T← to zero the balance. If using: place empty container on the weighing pan and press →0/T← to tare the balance.
- 7 Add the selected number of reference pieces to container.
- 8 Press and hold ↵ to confirm.

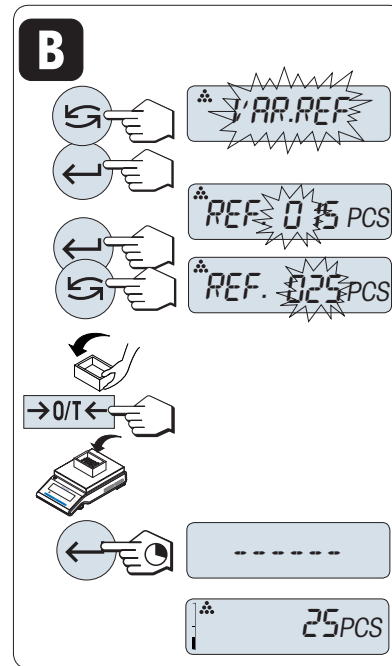

Legal-for-trade

* with approved balances in selected countries: min 10.

Setting the reference for one piece in weighing mode



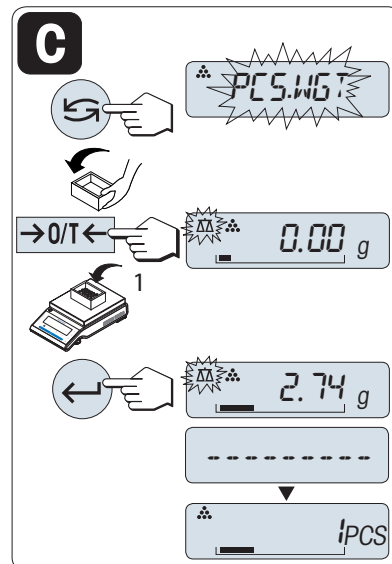

- 1 Select **PCS.WGT** by scrolling with ↻.
- 2 Press →0/T← to zero the balance. If using: place empty container on the weighing pan and press →0/T← to tare the balance.
- 3 Add one reference piece to container.
⇒ The weight of one piece is displayed.
- 4 Press ↵ to confirm.



Legal-for-trade

With approved balances, this setting is not available in selected countries.

Setting the reference for one piece in manual mode

- 1 Select **PCS.WGT** by scrolling with .
- 2 Press  to confirm.
- 3 Enter the final reference one piece weight.
- 4 Press  to select a digit (cyclically from left to right).
⇒ The selected digit is blinking.
- 5 Press  to change the digit.
- 6 Press and hold  to confirm.

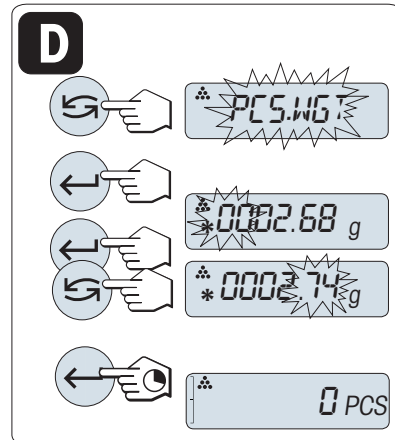

Legal-for-trade

With approved balances, this setting is not available in selected countries.

Note

If without any key press within 60 seconds or by pressing **C**, the balance returns to the previous active application.

On completion of the setting procedure, your balance is ready.

- The RECALL value is displayed with an asterisk (*) and icon **M** and can not be printed.
- Take into account minimum values: min. reference weight = 10d (10 digits), min. piece weight* = 1d (1 digit)!
* with approved balances in selected countries: min 3e
- The current reference weight remains stored until the reference setting is changed.



Terminate the application

Press and hold  to terminate the application and to return to the weighing application.

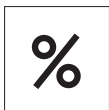
6.2 Application percent weighing



The **Percent weighing** application allows you to check a sample weight as percentage to a reference target weight.

- 1 Press and hold **F** to call-up **APP.LIST**.
- 2 Select application **PERCENT** by scrolling with .
- 3 Press  to activate the function.

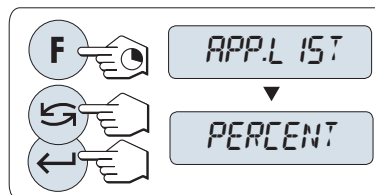



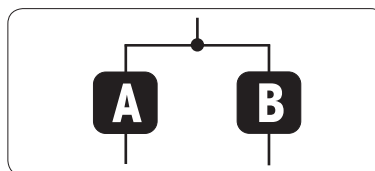

Percent weighing first requires the setting of a reference weight that should corresponds to 100%, there are 2 possibilities

- **A** Setting the reference **in manual mode (enter 100%)**.
- **B** Setting the reference **in weighing mode (weigh 100%)**.





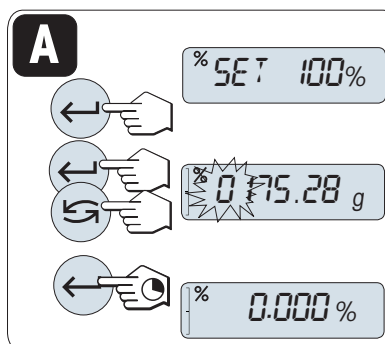

Setting the reference by manual mode (enter 100%)

- 1 Press  to activate manual mode.
- 2 Press  to select a digit (cyclically from left to right).
⇒ The selected digit is blinking.
- 3 Press  to change the digit.
- 4 Press and hold  to confirm.



Setting the reference by weighing mode (weigh 100%)

- 1 Press  **0/T**  to zero the balance. If using: place empty container on the weighing pan and press  **0/T**  to tare the balance.
- 2 Load the reference weight (100%). Reference weight must be at least +/- 10d.
- 3 Press  to confirm.

If without any key press within 60 seconds or by pressing **C**, the balance returns to the previous active application.

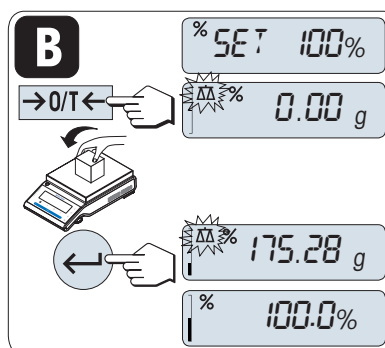

On completion of the setting procedure, your balance is ready.

Switching between percent and weight display

- Press  key at any time to switch the display between percent display, weighing unit **UNIT 1**, **RECALL** value (if activated) and weighing unit **UNIT 2** (if different from **UNIT 1**).

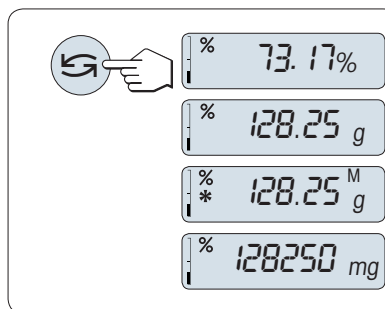

Terminate the application

Press and hold  to terminate the application and to return to the weighing application.

6.3 Application check weighing

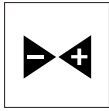

The **Check weighing** application allows you to check the deviation of a sample weight within a tolerance limit to a reference target weight.

- 1 Press and hold **F** to call-up **APP.LIST**.
- 2 Select application **CHECK** by scrolling with .
- 3 Press to activate the function.

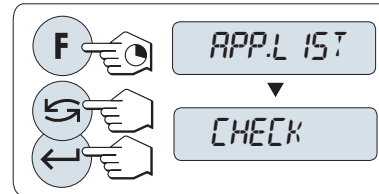

Step 1: Check weighing first requires the setting of a reference weight that should corresponds to the nominal weight, there are 2 possibilities

- **1A** Setting the reference **in manual mode** (enter nominal weight).
- **1B** Setting the reference **in weighing mode** (weigh nominal weight).

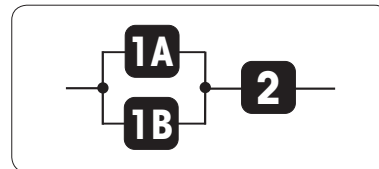

Step 2: Check weighing needs the upper and lower limits

- **2** Setting the **upper and lower limits in percentage**.

Setting the reference by manual mode (enter nominal weight)

- 1 Press to activate manual mode.
- 2 Select the reference target weight.
- 3 Press to select a digit (cyclically from left to right).
⇒ The selected digit is blinking.
- 4 Press to change the digit.
- 5 Press and hold to confirm.

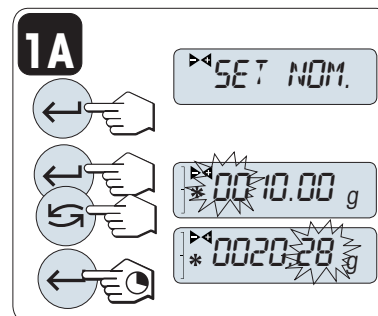

Setting the reference in weighing mode (weigh nominal weight)

- 1 Press **0/T** to zero the balance. If using: place empty container on the weighing pan and press **0/T** to tare the balance.
- 2 Load the nominal weight.
- 3 Press to confirm.

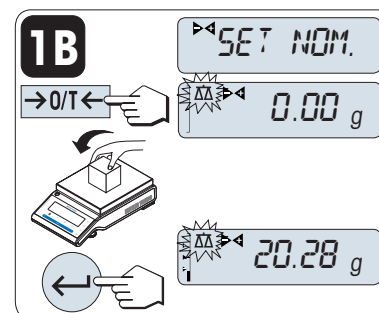

Setting the upper and lower limits (in percentage)

- 1 Press \leftarrow to start setting.
- 2 Press \leftarrow to confirm the default limit of +/- 2.5% or enter the limit value.
- 3 Press \leftarrow to select a digit (cyclically from left to right).
⇒ The selected digit is blinking.
- 4 Press \rightarrow to change the digit.
- 5 Press and hold \leftarrow to confirm.

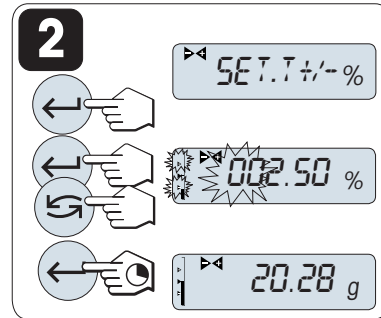

Note

If without any key press within 60 seconds or by pressing **C**, the balance returns to the previous active application.

The nominal weight must be at least 10 digit.

On completion of the setting procedure, your balance is ready.

Weighing-in-aid

The weighing-in-aid helps you quickly determine the position of the sample weight regarding the tolerance.

- **1** Lower limit
- **2** Target weight
- **3** Upper limit

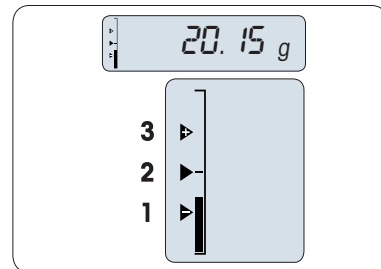



Terminate the application

Press and hold $\Delta\Delta$ to terminate the application and to return to the weighing application.

6.4 Application statistics



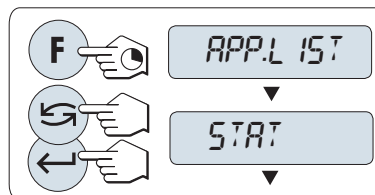

The **Statistics** application allows you to generate statistics of a series of weighing values. 1 to 999 values are possible.

- 1 Press and hold **F** to call-up **APP.LIST**.
- 2 Select application **STAT.** by scrolling with .
- 3 Press  to activate the function.





Memory clear question

If the memory is already cleared (sample counter is 0) the memory clear question will not be displayed.

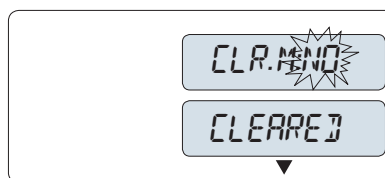
- 1 To continue the last statistics, press  to confirm **CLR.M:NO**.
- 2 For a new statistical evaluation clear the memory. Press  to select **CLR.M:YES** and press  to confirm.



Weighing the first sample weight

- 1 Press  **0**  to zero the balance.
- 2 Load the first sample weight.
- 3 Press .
 - ⇒ The display shows the sample count - **1** - and the current weight is stored as sample and the weight is printed out.
- 4 When the sample counter is displayed you may press and hold **C** to undo (drop) this sample.
- 5 Unload the first sample weight.

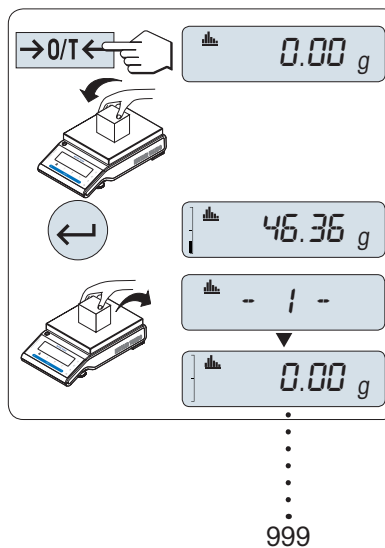

Weighing further sample weights

The same procedure as for the first sample weight.

- 1...999 samples are possible.
- The next value will be accepted if the sample weight is in the range 70% –130% of the current average value. OUT OF RANGE will be displayed if the sample is not accepted.

Results



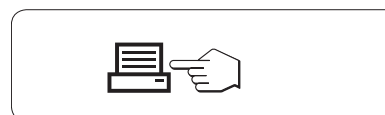















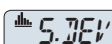













- Press , if the numbers of sample are greater than or equal to 2.
 - ⇒ The results are displayed and printed.



Displayed results

- 1 Press \leftarrow to show the next statistical value.
- 2 Press **C** to cancel displaying results and to continue weighing next sample.

0.5 seconds

number of samples				5	
average				50.530 g	
standard deviation				3.961 g	
relative standard deviation				7.84 %	
lowest value (minimum)				46.36 g	
highest value (maximum)				55.81 g	
different between the minimum and the maximum				9.45 g	
sum of all values				252.65 g	

Terminate the application



Press and hold $\overline{\Delta\Delta}$ to terminate the application and to return to the weighing application.

6.5 Application formulation (Net total formulation)



The **Formulation** (Net total) application allows you to

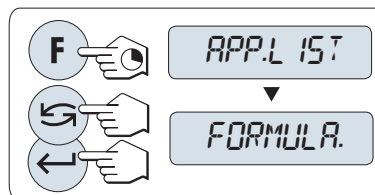

- weigh in (add and store) up to 999 individual component weights and displays the total. If a printer is connected, the component weights are printed individually and as a total.
- tare/pre-tare and store up to 999 container weights and displays the total. If a printer is connected, the tare weights are printed out individually and as a total.
- fill up the sum of all component net weight values by adding a further component to a higher value.

- Press and hold **F** to call-up **APP.LIST**.
- Select application **FORMULA.** by scrolling with .
- Press  to activate the function.



Memory clear question



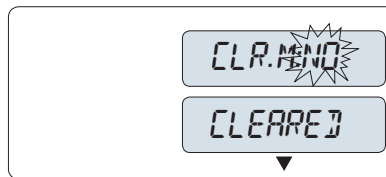

If the memory is already cleared (sample counter is 0) the memory clear question will not be displayed.

- To continue the last formulation weighing, press  to confirm **CLR.M:NO**.
- For a new formulation clear the memory. Press  to select **CLR.M:YES** and press  to confirm.



Tare container

If used.

- Press  **0/T**  to zero the balance. If using: place empty container on the weighing pan and press  **0/T**  to tare the balance.
 - ⇒ The container is tared and the tare count - **T1** - is displayed and the tare weight is printed.

If you pre-tare via MT-SIGS (e.g., bar code reader) - **PT1** - is displayed.

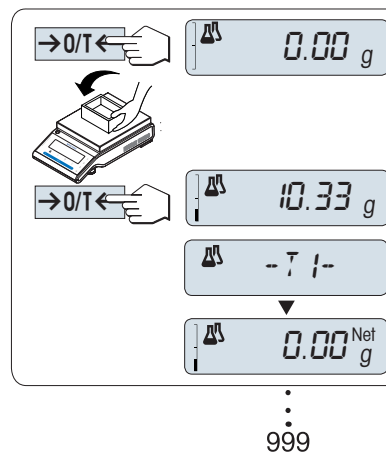

Zero range setting (menu topic "ZERO.RNG") has no effect. The zero-limit is less than or equal 10d.

Weighing the first component weight

- 1 Load the first component weight.
- 2 Press .
 - ⇒ The display briefly shows the component count - 1 -, the current weight is stored as sample and the component weight is printed. The display is set back to zero.

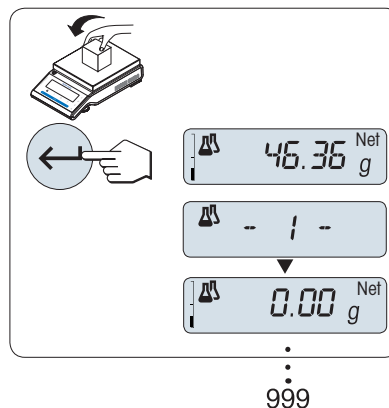

Weighing further component weights

The same procedure as for the first component weight with the same or new container).

- 1...999 sample values are possible.
- max 999 tare values are possible.
- max 999 pre-tare values are possible.





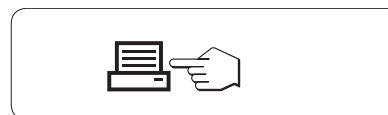



Results

- Press , if the numbers of sample are greater than or equal to 2.
 - ⇒ The results are displayed and printed.



Displayed results

- 1 Press  to show the next statistical value.
- 2 Press **C** to cancel displaying results and to continue weighing next component.

	0.5 seconds
number of samples	 N →  8 ←
sum of all tare values (T and PT)	 T.TOTAL →  452.76 g ←
sum of all component gross weight values	 G.TOTAL →  546.79 g ←
sum of all component net weight values	 N.TOTAL →  94.03 g ←

Function FILL UP

This function allows you to add an additional component weight to the total weight of all components to reach a desired target weight (Fill up).

Starting the fill up function

- Press  to activate or deactivate the function **FILL UP**.



Filling up with an additional component weight

- The last total of the component weights is displayed.
- 1 Add component weight until the desired target weight is reached.
- 2 Press \leftarrow to confirm.
- ⇒ The display briefly shows the next component count marked with **F**, the current weight is stored as sample and the component weight is printed. The display is set back to zero.

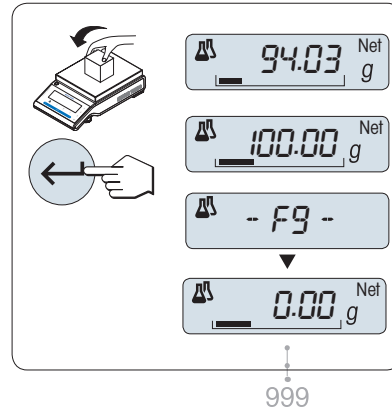

Filling up further additional component weights

The same procedure, beginning with starting up the FILL UP function.



Terminate the application

Press and hold $\Delta\Delta$ to terminate the application and to return to the weighing application.

6.6 Application totaling



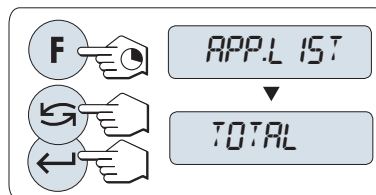

The **TOTALING** application allows you to weigh in different samples to add their weight values and to totalize them. 1 to 999 samples are possible.

- 1 Press and hold **F** to call-up **APP.LIST**.
- 2 Select application **TOTAL** by scrolling with .
- 3 Press  to activate the function.





Memory clear question

If the memory is already cleared (sample counter is 0) the memory clear question will not be displayed.

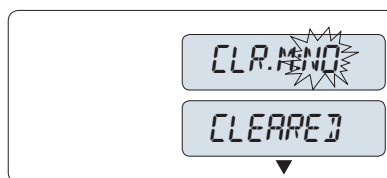
- 1 To continue the totaling evaluation, press  to confirm **CLR.M:NO**.
- 2 For a new totaling evaluation clear the memory. Press  to select **CLR.M:YES** and press  to confirm.



Weighing in the sample weight

- 1 Press  to zero the balance. If using: place empty container on the weighing pan and press  to tare the balance.
- 2 Load the first sample weight.
- 3 Press .
 - ⇒ The display shows the sample count - **1** - and the current weight is stored.
- 4 When the sample counter is displayed you may press and hold **C** to undo (drop) this sample.
- 5 Unload the first sample weight.
 - ⇒ The display shows zero.

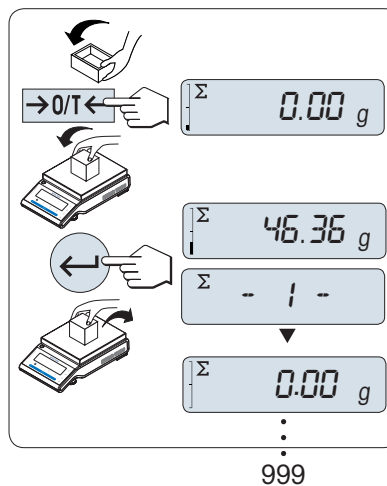

Weighing in further sample weights

The same procedure as for the first sample weight.

- 1...999 samples are possible.

Results

- Press , if the numbers of sample are greater than or equal to 2.
 - ⇒ The results are displayed and printed.

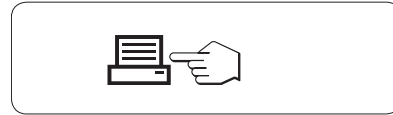

Displayed results

- 1 Press  to show the totalized value.
- 2 Press **C** to cancel.

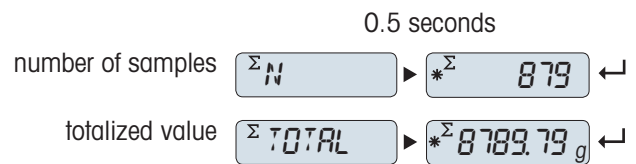



Terminate the application

Press and hold  to terminate the application and to return to the weighing application.

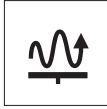
6.7 Application dynamic weighing



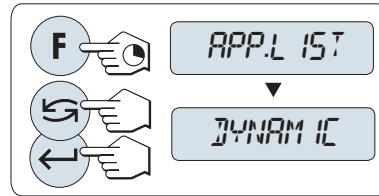

The **Dynamic weighing** application allows you to determine the weights of unstable samples or to determine weights under unstable ambient conditions. The balance calculates the weight as the average of a number of weighing operations over a defined time.

- 1 Press and hold **F** to call-up **APP.LIST**.
- 2 Select application **DYNAMIC** by scrolling with .
- 3 Press  to activate the function.





Setting auto start or manual start

The weighing starts automatically on relative stability. However, the weighing sample must weigh at least 5 grams. For weighing samples below 5 g the weighing must be started manually. Factory setting: MOD.AUTO (auto start).

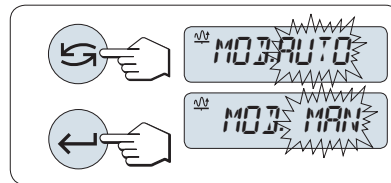
- 1 Press  to select the mode.
- 2 Select **MOD.AUTO** to starts automatically.
or
- 3 Select **MOD. MAN** to starts manually.
- 4 Press  to confirm.



Setting the weighing time

- 1 Press  to select one of the available time intervals:
3 (default value), 5, 10, 20, 60 and 120 seconds.
- 2 Press  to confirm.

Important: If without any key press within 60 seconds, the balance return to the previous active application. Press **C** to cancel and returns to the previous active application.

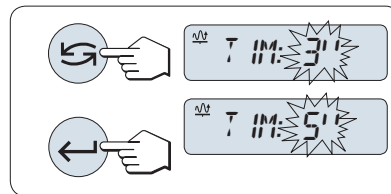

On completion of the setting procedure, your balance is ready.

- 1 Press $\rightarrow 0/T \leftarrow$ to zero the balance. If using: place empty container on the weighing pan and press $\rightarrow 0/T \leftarrow$ to tare the balance.
 - 2 Load sample weight.
 - 3 If you have selected function **M.START**, press \leftarrow to start the weighing.
or
 - 4 If you have selected function **A.START**, the weighing starts automatically on relative stability. For weighing samples below 5 g the weighing must be started manually by pressing \leftarrow .
 - 5 Read the result.
 \Rightarrow The result of the dynamic weighing is displayed with an asterisk (* = calculated value).
 - 6 Unload sample weight.
 - 7 **Manual Start** only, press $\rightarrow 0/T \leftarrow$ to zero the balance and go back to **M.START**.
- The remaining weighing time (in seconds) is displayed continuously. You can cancel the countdown by pressing **C**.
 - The weight value remains in the display until the sample weight is removed from weighing pan (auto start only) or $\rightarrow 0/T \leftarrow$ is pressed.

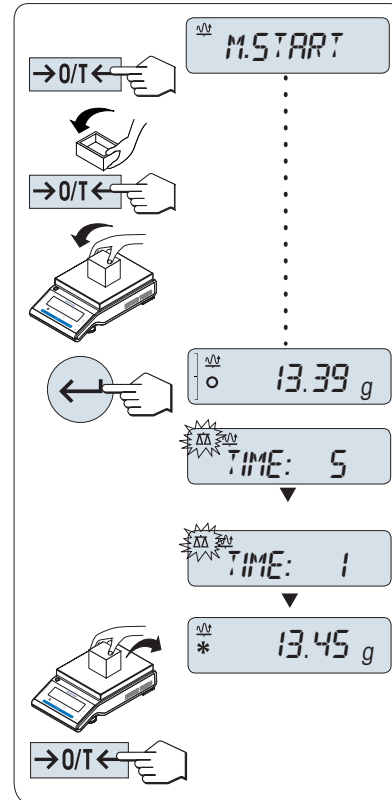



Terminate the application

Press and hold $\Delta\Delta$ to terminate the application and to return to the weighing application.

6.8 Application multiplication factor weighing





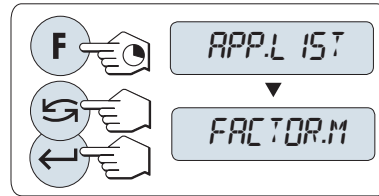

The **Multiplication factor weighing** application allows you to multiply the weight value (in grams) by a predefined factor (result = factor * weight) and have it calculated to a predefined number of decimal places.

- 1 Press and hold **F** to call-up **APP.LIST**.
- 2 Select application **FACTOR.M** by scrolling with .
- 3 Press  to activate the function.



Setting the factor value

Zero for multiplication factor value is outside the allowed range, the error message FACTOR OUT OF RANGE will be displayed.



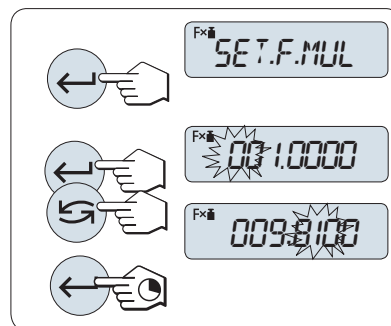

- 1 Press  to execute **SET.F.MUL**.
⇒ Either the factor 1 appears as default value or the factor that was saved most recently.
- 2 Press  to select a digit (cyclically from left to right).
⇒ The selected digit is blinking.
- 3 Press  to change the digit.
- 4 Press and hold  to confirm (no automatic acceptance).



Setting the step value

SET.STEP appears in the display, and the program changes automatically to allow the display increments to be entered. The smallest possible display increment appears as default value, or the last value that was saved.

The allowed range for the step depends on the factor and the resolution of the balance. If it is outside the allowed range the error message STEP OUT OF RANGE will be displayed.

- 1 Press  to execute **SET.STEP**.
- 2 Press  to select a digit (cyclically from left to right).
⇒ The selected digit is blinking.
- 3 Press  to change the digit.
- 4 Press and hold  to confirm (no automatic acceptance).

If without any key press within 60 seconds or by pressing **C**, the balance returns to the previous active application.

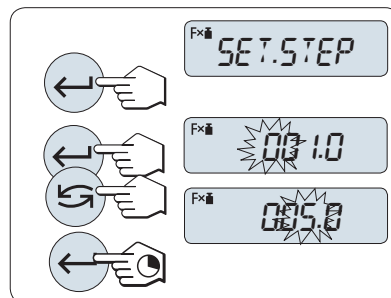

On completion of the setting procedure, your balance is ready.

Weighing procedure

- 1 Press $\rightarrow 0/T \leftarrow$ to zero the balance.
- 2 Load sample weight.
- 3 Read the result.
 - ⇒ The appropriate calculation is then made using the weight of sample and the selected factor, the result being displayed with the selected display step. No units are displayed.
- 4 Unload sample weight.

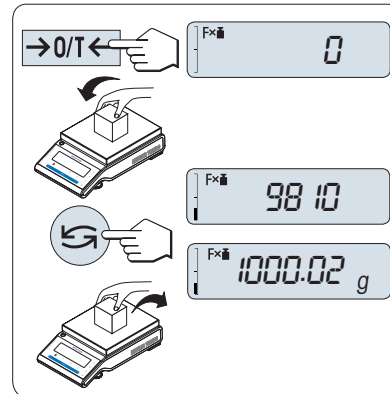

Toggling between displaying the calculated value and the measured weight

- Press \leftrightarrow key at any time to switch the display between percent display, weighing unit **UNIT 1**, **RECALL** value (if activated) and weighing unit **UNIT 2** (if different from **UNIT 1**).



Terminate the application

Press and hold $\Delta \Delta$ to terminate the application and to return to the weighing application.

6.9 Application division factor weighing





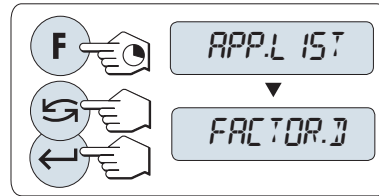

The **Division factor weighing** divide a predefined factor by the weight value (in grams) (result = factor / weight) and have it rounded to a predefined number of decimal places.

- 1 Press and hold **F** to call-up **APP.LIST**.
- 2 Select application **FACTOR.D** by scrolling with .
- 3 Press  to activate the function.



Setting the factor value

Zero for division factor value is outside the allowed range, the error message FACTOR OUT OF RANGE will be displayed.



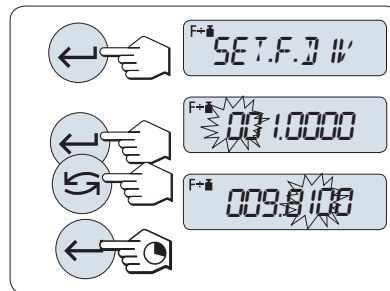

- 1 Press  to execute **SET.F.DIV**.
⇒ Either the factor 1 appears as default value or the factor that was saved most recently.
- 2 Press  to select a digit (cyclically from left to right).
⇒ The selected digit is blinking.
- 3 Press  to change the digit.
- 4 Press and hold  to confirm (no automatic acceptance).



Setting the step value

SET.STEP appears in the display, and the program changes automatically to allow the display increments to be entered. The smallest possible display increment appears as default value, or the last value that was saved.

The allowed range for the step depends on the factor and the resolution of the balance. If it is outside the allowed range the error message STEP OUT OF RANGE will be displayed.

- 1 Press  to execute **SET.STEP**.
- 2 Press  to select a digit (cyclically from left to right).
⇒ The selected digit is blinking.
- 3 Press  to change the digit.
- 4 Press and hold  to confirm (no automatic acceptance).

If without any key press within 60 seconds or by pressing **C**, the balance returns to the previous active application.

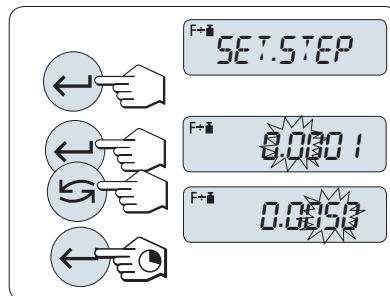

On completion of the setting procedure, your balance is ready.

Weighing procedure

- 1 Press $\rightarrow 0/T \leftarrow$ to zero the balance.
- 2 Load sample weight.
- 3 Read the result.
 - \Rightarrow The appropriate calculation is then made using the weight of sample and the selected factor, the result being displayed with the selected display step. No units are displayed.
- 4 Unload sample weight.

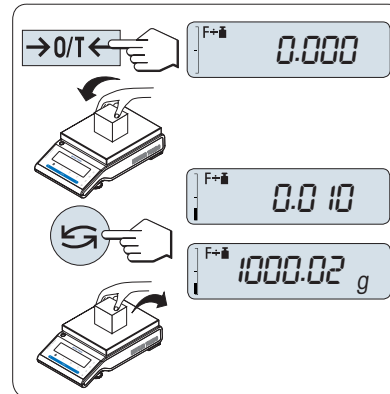

Toggling between displaying the calculated value and the measured weight

- Press \leftrightarrow key at any time to switch the display between percent display, weighing unit **UNIT 1**, **RECALL** value (if activated) and weighing unit **UNIT 2** (if different from **UNIT 1**).

Terminate the application

Press and hold $\Delta\Delta$ to terminate the application and to return to the weighing application.

6.10 Application density



The DENSITY application allows you to determine the density of solid bodies and liquids. Determination of the density uses **Archimedes' principle** according to which a body immersed in a fluid undergoes an apparent loss in weight which is equal to the weight of the fluid it displaces.



To determine the density of solid bodies, we recommend you to work with the optional density kit which contains all the attachments and aids needed for convenient and precise density determination. To determine the density of liquids, you additionally need a sinker which you can also obtain from your METTLER TOLEDO dealer.

Note for performing of density determinations

- You can also use the hanger for weighing below the balance which belongs to your balance.
- If a METTLER TOLEDO printer is attached to your balance, the settings will be automatically recorded.



We recommend you to consult the manual enclosed with the density kit.

- 1 Press and hold **F** to call-up **APP.LIST**.
- 2 Select application **DENSITY** by scrolling with .
- 3 Press  to activate the function.

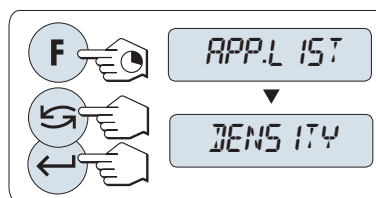

Setting the method for density determination

- 1 Select:
SOLID, the function for the density determination of solids, or
LIQUID, the function for the density determination of liquids with a sinker.
- 2 Press  to confirm.

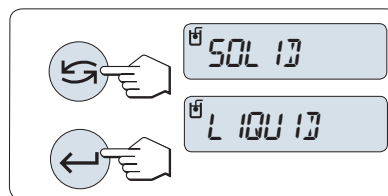



Terminate the application

Press and hold  to terminate the application and to return to the weighing application.



6.10.1 Density determination of solids

Setting the parameter of the auxiliary liquid

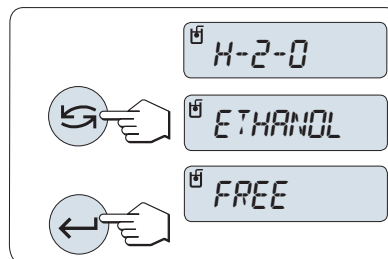
- Method **SOLID** is set.
- 1 Select the auxiliary liquid by scrolling with : **H-2-O** for distilled water, **ETHANOL** or **FREE** for a freely definable auxiliary liquid.
 - 2 Press  to confirm.



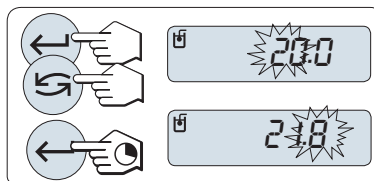

If you have selected water or ethanol as the auxiliary liquid

- 1 Enter the current temperature of the auxiliary liquid (read off on thermometer).
- 2 Set the value in °C. The temperature ranges from 10 °C to 30.9 °C.
- 3 Press  to select a digit (cyclically from left to right).
⇒ The selected digit is blinking.
- 4 Press  to change the digit.
- 5 Press and hold  to confirm.



The densities of distilled water and ethanol in the range 10°C to 30.9°C are stored in the balance.

If you have selected a freely definable auxiliary liquid

- 1 Enter the density of the auxiliary liquid at the current temperature (read off on thermometer).
- 2 Press  to select a digit (cyclically from left to right).
⇒ The selected digit is blinking.
- 3 To change the digit, press .
- 4 Press and hold  to confirm.

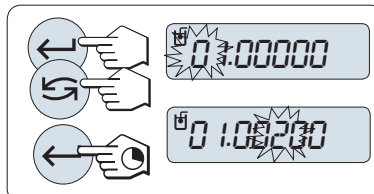

If without any key press within 60 seconds or by pressing **C**, the balance returns to the previous active application.

On completion of the setting procedure, your balance is ready.

Taring the balance is possible at any time.

The balance prompts you: PRESS ENTER TO START.

- Press  to start.

⇒ Tare/Zero is executed.

The balance prompts you to weigh the solid in air WEIGH IN AIR.

- 1 Load the solid.
- 2 Press  to initiate the measurement.

The balance prompts you to weigh the solid in the auxiliary liquid WEIGH IN LIQUID.

- 1 Load the solid.
- 2 Press  to initiate the measurement.
⇒ The balance now shows the determined density of the solid in g/cm³.

- This result has already been corrected for the air buoyancy. The buoyancy caused by the two immersed wires (∅ 0.6 mm) can be neglected.

- Press **C** the balance returns to **PRESS ENTER TO START**.

Result

- Press .
- ⇒ The result will be printed.

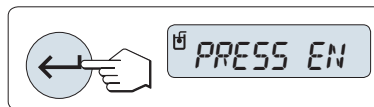

6.10.2 Density determination of liquids

Setting the displacement volume of your sinker

- Method **LIQUID** is set.
- 1 Press \leftarrow to confirm the default value of 10.0 cm³ or change it if needed.
- 2 Press \leftarrow to select a digit.
 - ⇒ The selected digit is blinking.
- 3 Press \leftarrow to change the digit.
- 4 Press and hold \leftarrow to confirm.

If without any key press within 60 seconds or by pressing **C**, the balance returns to the previous active application.

On completion of the setting procedure, your balance is ready.

Taring the balance is possible at any time.

The balance prompts you: PRESS ENTER TO START.

- Press \leftarrow to start.

The balance prompts you to weigh the sinker in air WEIGH IN AIR.

- 1 Position the sinker.
- 2 Press \leftarrow to initiate the measurement.

The balance prompts you to weigh the sinker in the liquid WEIGH IN LIQUID.

- 1 Pour the liquid into the beaker. Make sure that the sinker is immersed by at least 1 cm in the liquid, and that there are no air bubbles in the container.
 - 2 Press \leftarrow to initiate the measurement.
 - ⇒ The balance now shows the determined density of the liquid at the current temperature (read off on the thermometer).
- This result has already been corrected for the air buoyancy. The buoyancy caused by the immersed wire (\varnothing 0.2 mm) of the sinker can be neglected.
- Press **C** the balance returns to **PRESS ENTER TO START**.

Result

- Press \leftarrow .
- ⇒ The result will be printed.

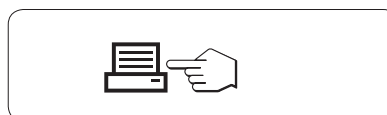
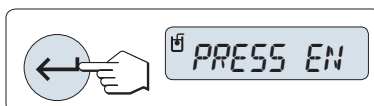
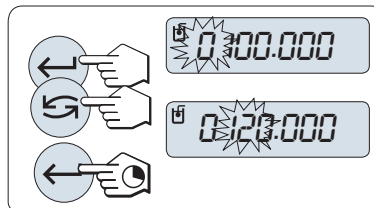

6.10.3 Formulae used to calculate density

The DENSITY application is based on the formulae listed below.

Formulae for determining the density of solids with compensation for air density

$$\rho = \frac{A}{A-B} (\rho_0 - \rho_L) + \rho_L$$

$$V = \alpha \frac{A - B}{\rho_0 - \rho_L}$$

- ρ = Density of the sample
 A = Weight of the sample in air
 B = Weight of the sample in the auxiliary liquid
 V = Volume of the sample
 ρ_0 = Density of the auxiliary liquid
 ρ_L = Density of air (0.0012 g/cm³)
 α = Weight correction factor (0.99985), to take the atmospheric buoyancy of the adjustment weight into account

Formula for determining the density of liquids with compensation for air density

$$\rho = \alpha \frac{P}{V} + \rho_L$$

- ρ = Density of the liquid
 P = Weight of the displaced liquid
 V = Volume of the sinker
 ρ_L = Density of air (0.0012 g/cm³)
 α = Weight correction factor (0.99985), to take the atmospheric buoyancy of the adjustment weight into account

T/°C	0.0	0.1	0.2	0.3	0.4	0.5	0.6	0.7	0.8	0.9
10.	0.99973	0.99972	0.99971	0.99970	0.99969	0.99968	0.99967	0.99966	0.99965	0.99964
11.	0.99963	0.99962	0.99961	0.99960	0.99959	0.99958	0.99957	0.99956	0.99955	0.99954
12.	0.99953	0.99951	0.99950	0.99949	0.99948	0.99947	0.99946	0.99944	0.99943	0.99942
13.	0.99941	0.99939	0.99938	0.99937	0.99935	0.99934	0.99933	0.99931	0.99930	0.99929
14.	0.99927	0.99926	0.99924	0.99923	0.99922	0.99920	0.99919	0.99917	0.99916	0.99914
15.	0.99913	0.99911	0.99910	0.99908	0.99907	0.99905	0.99904	0.99902	0.99900	0.99899
16.	0.99897	0.99896	0.99894	0.99892	0.99891	0.99889	0.99887	0.99885	0.99884	0.99882
17.	0.99880	0.99879	0.99877	0.99875	0.99873	0.99871	0.99870	0.99868	0.99866	0.99864
18.	0.99862	0.99860	0.99859	0.99857	0.99855	0.99853	0.99851	0.99849	0.99847	0.99845
19.	0.99843	0.99841	0.99839	0.99837	0.99835	0.99833	0.99831	0.99829	0.99827	0.99825
20.	0.99823	0.99821	0.99819	0.99817	0.99815	0.99813	0.99811	0.99808	0.99806	0.99804
21.	0.99802	0.99800	0.99798	0.99795	0.99793	0.99791	0.99789	0.99786	0.99784	0.99782
22.	0.99780	0.99777	0.99775	0.99773	0.99771	0.99768	0.99766	0.99764	0.99761	0.99759
23.	0.99756	0.99754	0.99752	0.99749	0.99747	0.99744	0.99742	0.99740	0.99737	0.99735
24.	0.99732	0.99730	0.99727	0.99725	0.99722	0.99720	0.99717	0.99715	0.99712	0.99710
25.	0.99707	0.99704	0.99702	0.99699	0.99697	0.99694	0.99691	0.99689	0.99686	0.99684
26.	0.99681	0.99678	0.99676	0.99673	0.99670	0.99668	0.99665	0.99662	0.99659	0.99657
27.	0.99654	0.99651	0.99648	0.99646	0.99643	0.99640	0.99637	0.99634	0.99632	0.99629
28.	0.99626	0.99623	0.99620	0.99617	0.99614	0.99612	0.99609	0.99606	0.99603	0.99600
29.	0.99597	0.99594	0.99591	0.99588	0.99585	0.99582	0.99579	0.99576	0.99573	0.99570
30.	0.99567	0.99564	0.99561	0.99558	0.99555	0.99552	0.99549	0.99546	0.99543	0.99540

Density of H₂O given in g/cm³, according to the "American Institute of Physics Handbook".

T/°C	0.0	0.1	0.2	0.3	0.4	0.5	0.6	0.7	0.8	0.9
10.	0.79784	0.79775	0.79767	0.79758	0.79750	0.79741	0.79733	0.79725	0.79716	0.79708
11.	0.79699	0.79691	0.79682	0.79674	0.79665	0.79657	0.79648	0.79640	0.79631	0.79623
12.	0.79614	0.79606	0.79598	0.79589	0.79581	0.79572	0.79564	0.79555	0.79547	0.79538
13.	0.79530	0.79521	0.79513	0.79504	0.79496	0.79487	0.79479	0.79470	0.79462	0.79453
14.	0.79445	0.79436	0.79428	0.79419	0.79411	0.79402	0.79394	0.79385	0.79377	0.79368
15.	0.79360	0.79352	0.79343	0.79335	0.79326	0.79318	0.79309	0.79301	0.79292	0.79284
16.	0.79275	0.79267	0.79258	0.79250	0.79241	0.79232	0.79224	0.79215	0.79207	0.79198
17.	0.79190	0.79181	0.79173	0.79164	0.79156	0.79147	0.79139	0.79130	0.79122	0.79113
18.	0.79105	0.79096	0.79088	0.79079	0.79071	0.79062	0.79054	0.79045	0.79037	0.79028
19.	0.79020	0.79011	0.79002	0.78994	0.78985	0.78977	0.78968	0.78960	0.78951	0.78943
20.	0.78934	0.78926	0.78917	0.78909	0.78900	0.78892	0.78883	0.78874	0.78866	0.78857
21.	0.78849	0.78840	0.78832	0.78823	0.78815	0.78806	0.78797	0.78789	0.78780	0.78772
22.	0.78763	0.78755	0.78746	0.78738	0.78729	0.78720	0.78712	0.78703	0.78695	0.78686
23.	0.78678	0.78669	0.78660	0.78652	0.78643	0.78635	0.78626	0.78618	0.78609	0.78600
24.	0.78592	0.78583	0.78575	0.78566	0.78558	0.78549	0.78540	0.78532	0.78523	0.78515
25.	0.78506	0.78497	0.78489	0.78480	0.78472	0.78463	0.78454	0.78446	0.78437	0.78429
26.	0.78420	0.78411	0.78403	0.78394	0.78386	0.78377	0.78368	0.78360	0.78351	0.78343
27.	0.78334	0.78325	0.78317	0.78308	0.78299	0.78291	0.78282	0.78274	0.78265	0.78256
28.	0.78248	0.78239	0.78230	0.78222	0.78213	0.78205	0.78196	0.78187	0.78179	0.78170
29.	0.78161	0.78153	0.78144	0.78136	0.78127	0.78118	0.78110	0.78101	0.78092	0.78084
30.	0.78075	0.78066	0.78058	0.78049	0.78040	0.78032	0.78023	0.78014	0.78006	0.77997

Density of C₂H₅OH given in g/cm³, according to the "American Institute of Physics Handbook".

7 Communication with Peripheral Devices

7.1 PC-Direct function

The numerical value displayed at the balance can be transferred to the cursor position in windows applications, e.g., Excel, Word in the same way as typing with the keyboard.

The weight value without the unit will be transferred.

Requirements

- PC with one of the following Microsoft Windows® 32-bit/64-bit operating systems: Win 7 (SP1), Win 8 or Win 10
- Serial interface RS232C or USB
- Administrator rights for installing the SerialPortToKeyboard software (if data transfer is via RS232C)
- Windows application, e.g., Excel
- Connection between balance and PC via cable RS232C or USB

Installing SerialPortToKeyboard software

The operation of PC-Direct via serial port RS232C requires the installation of **SerialPortToKeyboard** on your host computer. The file **SerialPortToKeyboard** can be found on www.mt.com/labweighing-software-download. If you have any questions, please contact a METTLER TOLEDO representative.

Download SerialPortToKeyboard

- 1 Connect to the internet.
- 2 Go to the site www.mt.com/labweighing-software-download.
- 3 Click **Download Software and Instructions** in section **SerialPortToKeyboard software for Advanced and Standard level laboratory balances**.
 - ⇒ A pop-up window with interactions appears.
- 4 Click, e.g., **Open**.
 - ⇒ The extract screen appears.
- 5 Extract the file **SerialPortToKeyboard_V_x.xx_installer_and_instructions.zip** to your specified location.
- 6 Right-click on the downloaded installation program **SerialPortToKeyboard_V_x.xx.exe** and select **Run as Administrator**.
- 7 If a safety warning appears, confirm windows to perform the installation.
- 8 Click **Next** and follow the installer's instructions.

Checking operation

- 1 Start **SerialPortToKeyboard** (RS232C)
- 2 Start Excel (or another application) at the PC.
- 3 Activate a cell in Excel.

Settings at the PC

Settings for SerialPortToKeyboard

- 1 Select the serial port **COM** for the connection with the balance.
 - 2 Set the **Baud Rate** to **9600**.
 - 3 Activate **Connect**.
- Closing the window terminates the session.

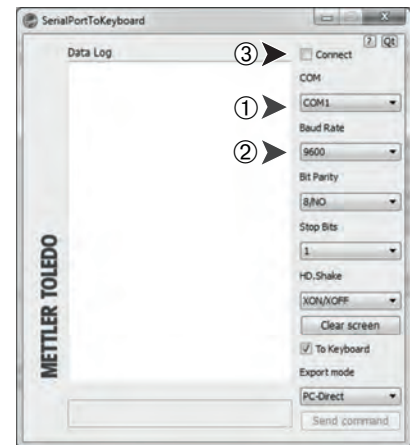

Settings at the balance

Balance interface settings, **see** "Interface menu".

- Topic RS232 or **USB**: set PC-DIR. and select the most appropriate option for the desired weighing result.
- Topic RS.TX.E.O.L./RS E.O.L. or USB E.O.L./USB E.O.L:
 - set **<TAB>** to write into the same row (e.g. in Excel).
 - set **<CR><LF>** to write into the same column (e.g. in Excel).
- Save changes.





















According to your selected PC-DIR. option, the displayed values will appear e.g. in the column one after the other one in the different rows.

7.2 Send weight value via RS232 to a PC using EasyDirect balance

The software EasyDirect Balance collects weighing results and additional data such as the date, time and the measurement unit. The data can be printed or saved in various data formats on a PC, e.g. as PDF or Excel file. The software can be ordered at METTLER TOLEDO and must be installed on a PC.

- EasyDirect Balance is installed on the PC according to the user requirements.
- The balance is connected to the PC via RS232 interface.

Configure balance

- 1 Press and hold .
⇒ The menu **BASIC** appears.
- 2 Press  repeatedly until the menu **INT.FACE** appears.
- 3 Press .
⇒ The menu topic **RS232** appears.
- 4 Press .
⇒ **PRINTER** appears.
- 5 Press .
- 6 Press  repeatedly and select a suitable mode, e.g. **PRT.STAB**.
- 7 Press  to confirm the selection.
⇒ The previously chosen menu topic appears.
- 8 Press .
⇒ The menu topic **HEADER** appears.
- 9 Press .
- 10 Press  repeatedly until **D/T/BAL** appears.
- 11 Press  to confirm the selection.
⇒ The previously chosen menu topic appears.
- 12 Press .
⇒ The menu topic **SINGLE** appears.
- 13 Press .
- 14 Press  repeatedly until **G / T / N** appears.
- 15 Press  to confirm the selection.
⇒ The previously chosen menu topic appears.
- 16 Press .
⇒ The menu topic **SIGN.L** appears.
- 17 Press .
- 18 Press  repeatedly until **ON** appears.
- 19 Press  to confirm the selection.
⇒ The previously chosen menu topic appears.
- 20 Press and hold .
⇒ **SAVE:YES** appears.
- 21 Press  to confirm the selection.
⇒ Changes are saved.

Note

If no changes have been made, the balance will switch to the weighing mode at step 20.

Transfer values

- 1 Start EasyDirect Balance on your PC.
- 2 Refer to the EasyDirect Balance Help menu to add the balance and to set up the connection.

- 3 Place the sample on the weighing pan.
 - ⇒ The weighing result is transferred to EasyDirect Balance either automatically or when the print icon is pressed. This depends on the settings in the publishing menu of the balance.

8 Maintenance

To guarantee the functionality of the balance and the accuracy of the weighing results, a number of maintenance actions must be performed by the user.

8.1 Maintenance table

Maintenance action	Recommended interval	Remarks
Performing an internal adjustment	<ul style="list-style-type: none">• Daily• After cleaning• After leveling• After changing the location	see chapter "Adjustment with internal weight"
Performing routine tests (sensitivity test, repeatability test). METTLER TOLEDO recommends to perform at least a sensitivity test.	<ul style="list-style-type: none">• After cleaning	see below
Cleaning	Depending on the degree of pollution or your internal regulations (SOP), clean the instrument: <ul style="list-style-type: none">• After every use• After change of sample	see chapter "Cleaning the balance"

8.2 Performing routine tests

There are several routine tests. Depending on your internal regulations, specific routine test must be performed by the user.

METTLER TOLEDO recommends to perform an sensitivity test after cleaning and reassembling the balance.

8.3 Cleaning



WARNING

Death or serious injury due to electric shock

Contact with parts carrying a live current can lead to injury and death.

- 1 Disconnect the instrument from the power supply prior to cleaning and maintenance.
- 2 Prevent liquid from entering the instrument, terminal or AC/DC adapter.

8.3.1 Cleaning agents

The following table presents the cleaning tools and cleaning agents recommended by METTLER TOLEDO.

		Tools					Cleaning agents					
		Paper tissue	Brush	Dishwasher	Water	Acetone	Ethanol (70%)	Isopropanol (70%)	Hydrochloric acid (3-10 %)	Sodiumhydroxide (0.2-1.0 M)	Peracetic acid (2-3%)	
Around the balance	Balance housing	✓	—	—	R	—	R	✓	R	R	R	
	Top housing	✓	—	—	R	—	R	✓	R	R	R	
	Housing	✓	—	—	R	—	R	✓	R	R	R	
	Back housing	✓	—	—	R	—	R	✓	R	—	R	
	Feet	R	—	—	R	—	R	✓	R	R	R	
Display	Screen / display	✓	—	—	✓	—	R	R	R	R	R	
Balance draft shield	Glass panels	R	—	✓	R	—	R	R	R	R	R	
	Glass free panels	R	—	—	R	—	✓	R	R	R	R	
	Non-removable handles and frames	✓	—	—	R	—	—	✓	R	R	R	
Weighing area	Draft ring element / Draft shield element	R	—	✓	R	—	—	—	R	—	R	
	Weighing pan	✓	—	—	R	—	✓	R	R	R	R	

Symbol descriptions:

✓: Best recommendation by METTLER TOLEDO, can be used without limitation.

R: Recommended by METTLER TOLEDO, can be used without limitation.

(D): Depending on the material used: individual durability and resistance to acid and alkali must be evaluated.

— Not recommended.

8.3.2 Cleaning the glass draft shield



CAUTION

Injury due to breaking glass

Careless handling of the glass components can lead to breakage off glass and damage cuttings.

- Always proceed focused and with care.

Removing or inserting sliding glass doors

It is possible to remove the sliding glass doors for cleaning or for replacing.

Note

Front and rear glass panels cannot be removed.

- 1 Remove the handle first.
- 2 Remove the sliding glass doors.
- 3 Install the handle after insertion of the glass door.

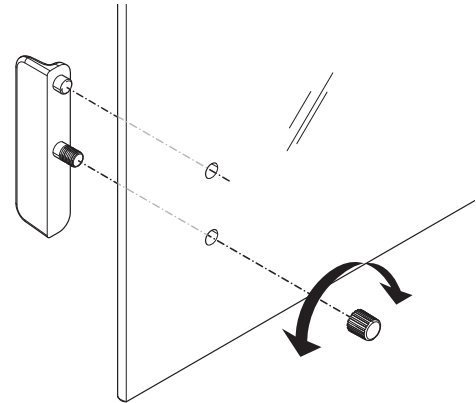

8.3.3 Cleaning the balance



NOTICE

Damage due to improper cleaning

Improper cleaning can damage the load cell or other essential parts.

- 1 Do not use any cleaning agents other than the ones specified in the "Reference Manual" or "Cleaning Guide".
- 2 Do not spray or pour liquids on the instrument. Always use a moistened lint-free cloth or a tissue.
- 3 Always wipe out from inside to outside of the instrument.

Cleaning around the balance

- Remove any dirt or dust around the balance and avoid further contaminations.

Cleaning the removable parts

- Clean the removed part with a damp cloth or a tissue and a mild cleaning agent.

Cleaning the balance

- 1 Disconnect the balance from the AC/DC adapter.
- 2 Use a lint-free cloth moistened with a mild cleaning agent to clean the surface of the balance.
- 3 Remove powder or dust at first with a disposable tissue.
- 4 Remove sticky substances with a damp lint-free cloth and a mild solvent.

Note



Useful details to avoid soiling the instrument are described in the Mettler-Toledo GmbH "SOP for Cleaning a Balance".

8.3.4 Putting into operation after cleaning

- 1 Reassemble the balance.
- 2 Check the functionality of the draft shield if applicable.
- 3 Press  to switch on the balance.
- 4 Warm up the balance. Wait 1h for the acclimatization, before starting the tests.
- 5 Check the level status, level the balance if necessary.
- 6 Perform an adjustment (internal or external).

- 7 Perform a routine test due to the internal regulations of your company. METTLER TOLEDO recommends to perform an repeatability test after cleaning the balance.
 - 8 Press **→0/T←** to zero the balance.
- ⇒ The balance has been put into operation and is ready to use.

See also

-  Adjustment (calibration) ▶ Page 21
-  Leveling the balance ▶ Page 19

9 Troubleshooting

Possible errors with their cause and remedy are described in the following chapter. If there are errors that cannot be corrected through these instructions, contact METTLER TOLEDO.

9.1 Error messages

Error message	Possible cause	Diagnostic	Remedy
NO STABILITY	Vibrations at the workplace.	Place beaker with tap water on the weighing table. Vibrations cause ripples on the water surface.	<ul style="list-style-type: none"> Protect weighing location against vibrations (vibration absorber, etc.). Set weighing parameters coarser (change ENVIRON. from STABLE to STANDARD or even UNSTABLE. Find a different weighing location.
	Draft due to untight draft shield and /or open window.	Make sure draft shield or window is closed.	<ul style="list-style-type: none"> Close draft shield or window. Set weighing parameters coarser (change ENVIRON. from STABLE to STANDARD or even UNSTABLE.
	The location is not suitable for weighing.	–	Check and observe the requirements for the location, refer to "Selecting the location".
	Something is touching the weighing pan.	Check for touching parts or dirt.	Remove touching parts or clean the balance.
WRONG ADJUSTMENT WEIGHT	Wrong adjustment weight.	Check weight.	Place correct weight on the weighing pan.
REFERENCE TOO SMALL	Reference for piece counting too small.	–	Increase reference weight.
EEPROM ERROR - PLEASE CONTACT CUSTOMER SERVICE	Data in EEPROM damaged.	–	Please contact your METTLER TOLEDO customer service.
WRONG CELL DATA - PLEASE CONTACT CUSTOMER SERVICE	Defect load cell data.	–	Please contact your METTLER TOLEDO customer service.
NO STANDARD ADJUSTMENT - PLEASE CONTACT CUSTOMER SERVICE	–	–	Please contact your METTLER TOLEDO customer service.
PROGRAM MEMORY DEFECT - PLEASE CONTACT CUSTOMER SERVICE	–	–	Please contact your METTLER TOLEDO customer service.

Error message	Possible cause	Diagnostic	Remedy
TEMP SENSOR DEFECT - PLEASE CONTACT CUSTOMER SERVICE	AC/DC adapter connected to power before connecting to the balance. Temperature sensor of load cell defect.	–	Remove the AC/DC adapter from the power and connect first to the balance before connecting to the power if persist please contact your METTLER TOLEDO customer service.
WRONG LOAD CELL BRAND - PLEASE CONTACT CUSTOMER SERVICE	Wrong load cell installed.	–	Please contact your METTLER TOLEDO customer service.
WRONG TYPE DATA SET - PLEASE CONTACT CUSTOMER SERVICE	Wrong type data set.	–	Please contact your METTLER TOLEDO customer service.
BATTERY BACKUP LOST - CHECK DATE TIME SETTINGS	Backup battery/capacitor is empty. This battery/capacitor ensures that the date and time are not lost when the balance is disconnected from power.	The battery/capacitor provides enough power for approximately 2 days when having the balance not connected to the power supply.	Connect the balance to the power supply for charging the battery (e.g., during the night) or contact METTLER TOLEDO customer service.
ABOVE INITIAL ZERO RANGE	Wrong weighing pan. Pan is not empty.	Check weighing pan.	Mount correct weighing pan or unload weighing pan.
BELOW INITIAL ZERO RANGE	Wrong weighing pan. Pan is missing.	Check weighing pan.	Mount correct weighing pan.
MEM FULL	Memory full.	–	Clear the memory by finishing all applications where a measurement is ongoing.
FACTOR OUT OF RANGE	Factor is outside the allow range.	–	Select a new factor.
STEP OUT OF RANGE	Step is outside the allow range.	–	Select a new step.
OUT OF RANGE	Sample weight is outside the allow range.	–	Unload the pan and load a new sample weight.

9.2 Error symptoms

Error symptom	Possible cause	Diagnostic	Remedy
Display is dark	Instrument is switched off.	–	Switch on the instrument.
	Power plug not connected.	Check	Connect power cable to power supply.
	Power supply not connected to balance.	Check	Connect power supply.
	Power supply is faulty.	Check/test	Replace power supply.
	Wrong power supply.	Check that input data on type plate match the power supply values.	Use proper power supply.
	Connector socket on balance is corroded or faulty.	Check	Please contact your METTLER TOLEDO customer service.

Error symptom	Possible cause	Diagnostic	Remedy
	Display is faulty.	Replace display.	Please contact your METTLER TOLEDO customer service.
Operation Keys do not work	Keypad is defect.	Replace the keypad.	Please contact your METTLER TOLEDO customer service.
The value drifts into plus or minus	Room, environment not suitable.	–	Environmental recommendations <ul style="list-style-type: none"> • Windowless, non air-conditioned room, e.g., basement. • Only one person in the weighing room. • Sliding doors. Standard doors cause pressure changes. • No draft in weighing room (check with suspended threads). • No air conditioning (temperature oscillates, draft). • Acclimatize balance, take dummy measurements. • Instrument uninterruptedly connected to the power supply (24h per day).
	Direct sunlight or other heat source.	Is any sun shade (blinds, curtains, etc.) available?	Select location according to "Selecting the location" (customer responsibility).
	Weighing sample absorbs moisture or evaporates moisture.	<ul style="list-style-type: none"> • Is the weighing result with a test weight stable? • Sensitive weighing samples, e.g., paper, cardboard, wood, plastic, rubber, liquids. 	<ul style="list-style-type: none"> • Use aids. • Cover weighing sample.
	Weighing sample is electrostatically charged.	<ul style="list-style-type: none"> • Is the weighing result with a test weight stable? • Sensitive weighing samples, e.g., plastic, powder, insulating materials. 	<ul style="list-style-type: none"> • Increase air humidity in weighing chamber (45% - 50%). • Use ionizer.
	Weighing sample is hotter or colder than the air in the weighing chamber.	Weighing operation with test weight does not show this effect.	Bring weighing sample to room temperature before weighing.

Error symptom	Possible cause	Diagnostic	Remedy
	Instrument has not yet reached thermal equilibrium.	<ul style="list-style-type: none"> Was there a power outage? Was power supply disconnected? 	<ul style="list-style-type: none"> Acclimatize instrument for at least 1 hour. Depending on climatic conditions, extend this period accordingly. Instrument switched on for at least 1 hour, refer to "General data"
Display shows overload or underload	The weight on the weighing pan exceeds the weighing capacity of the instrument.	Check weight.	Reduce the weight on the weighing pan.
	Wrong weighing pan.	Slightly lift or press weighing pan. The weight display appears.	Use proper weighing pan.
	No weighing pan.	–	Install weighing pan.
	Incorrect zero point at switch-on.	–	<ul style="list-style-type: none"> Switch off balance. Disconnect and reconnect power cable.
Display flashes 0.0000	Loose cables.	Check all cable connections.	Connect all cables. Please contact your METTLER TOLEDO customer service if the problem persists.
Taring not possible	Vibrations at the workplace.	Display unstable.	Press Tare again.
		Place beaker with tap water on the weighing table. Vibrations cause ripples on the water surface.	<ul style="list-style-type: none"> Protect weighing location against vibrations (vibration absorber, etc.). Set weighing parameters coarser (change ENVIRON. from STABLE to STANDARD or even UNSTABLE). Find a different weighing location (by agreement with customer).

9.3 Status messages/Status icons

Status messages are displayed by means of small icons. The status icons indicate the following:

Icon	Status description	Diagnostic	Remedy
	Service due.	See menu topic SERV.ICON in chapter "Description of menu topic" -> "Advanced menu".	Please contact your METTLER TOLEDO-Support representative.

9.4 Putting into operation after fixing an error

After fixing an error, perform the following steps to put the balance into operation:

- Ensure that the balance is completely reassembled and cleaned.
- Reconnect the balance to the AC/DC adapter.

10 Technical Data

10.1 General data

Standard power supply

AC/DC adapter:	Input: 100 – 240 V AC \pm 10%, 50 – 60 Hz, 0.5 A, 24 – 34 VA Output: 12 V DC, 1.0 A, LPS (Limited Power Source)
Polarity:	
Balance power consumption:	12 V DC, 0.3 A If the balance is used above 2000 m mean sea level, the optional power supply must be used.

Optional power supply

AC/DC adapter:	Input: 100 – 240 V AC \pm 10%, 50 – 60 Hz, 0.8 A, 60 – 80 VA Output: 12 V DC, 2.5 A, LPS (Limited Power Source)
Cable for AC/DC adapter:	3-core, with country-specific plug
Polarity:	
Balance power consumption:	12 V DC, 0.3 A

Protection and standards

Overvoltage category:	II
Degree of pollution:	2
Protection:	Protected against dust and water
Standards for safety and EMC:	See Declaration of Conformity
Range of application:	Use only indoors in dry locations

Environmental conditions

Height above mean sea level:	Up to 2000 m (standard power supply) Up to 4000 m (optional power supply)
Ambient temperature:	+5 °C – +40 °C
Storage condition:	-25 °C – +70 °C
Relative air humidity:	Max. 80% up to 31 °C, linearly decreasing to 50% at 40 °C, non-condensing
Warm-up time:	At least 30 minutes (0.1 mg / 0.01 mg models 60 minutes) after connecting the balance to the power supply.

Materials

Housing:	Top Housing: ABS Bottom housing: Die-cast aluminum, lacquered
Weighing pan:	ø 80 mm and 90 mm: Stainless steel X2CrNiMo 17-12-2 (1.4404) All others: Stainless steel X5CrNi 18-10 (1.4301)
Draft shield element:	0.1 mg models: Stainless steel X5CrNi 18-10 (1.4301)
Draft shield:	ABS, glass
Protective cover:	PET
Backup battery:	Capacitor (saves date and time for approximately two days)

10.2 Model-specific data

10.2.1 Balances with readability of 0.01 mg with draft shield

	ME155DU	ME55
Limit values		
Capacity	152 g	52 g
Nominal load	140 g	50 g
Readability	0.1 mg	0.01 mg
Capacity of fine range	42 g	–
Readability in fine range	0.01 mg	–
Repeatability	0.1 mg	0.03 mg
Repeatability in fine range	0.03 mg	–
Linearity deviation	0.2 mg	0.1 mg
Eccentricity deviation (at test load)	0.2 mg (50 g)	0.1 mg (20 g)
Sensitivity offset (at nominal load) ¹⁾	0.8 mg	0.4 mg
Sensitivity temperature drift ²⁾	0.0002 %/°C	0.0002 %/°C
Typical values		
Repeatability	0.08 mg	0.02 mg
Repeatability in fine range	0.02 mg	–
Linearity deviation	0.10 mg	0.05 mg
Eccentricity deviation (at test load)	0.15 mg (50 g)	0.08 mg (20 g)
Minimum weight (USP, tolerance = 0.10%) ³⁾	40 mg	40 mg
Minimum weight (tolerance = 1%) ³⁾	4 mg	4 mg
Settling time	8 s	8 s
Adjustment	Internal	Internal
Balance dimensions (W × D × H)	210 × 344 × 344 mm	210 × 344 × 344 mm
Weighing pan diameter	80 mm	80 mm
Usable height of draft shield	235 mm	235 mm
Balance weight	4.7 kg	4.7 kg
Weights for routine testing		
Weights (OIML class)	5 g (F2) / 100 g (F2)	5 g (F2) / 50 g (F2)
Weights (ASTM class)	5 g (ASTM 1) / 100 g (ASTM 1)	5 g (ASTM 1) / 50 g (ASTM 1)

¹⁾ after sensitivity adjustment

²⁾ In the temperature range +10 °C – +30 °C

³⁾ determined at 5% load, k = 2

10.2.2 Balances with readability of 0.1 mg with draft shield

	ME54	ME54E
Limit values		
Capacity	52 g	52 g
Nominal load	50 g	50 g
Readability	0.1 mg	0.1 mg
Repeatability	0.1 mg	0.1 mg
Linearity deviation	0.2 mg	0.2 mg
Eccentricity deviation (at test load)	0.3 mg (20 g)	0.3 mg (20 g)
Sensitivity offset (at nominal load) ¹⁾	0.6 mg	0.6 mg
Sensitivity temperature drift ²⁾	0.0002 %/°C	0.0002 %/°C
Typical values		
Repeatability	0.08 mg	0.08 mg
Linearity deviation	0.06 mg	0.06 mg
Eccentricity deviation (at test load)	0.15 mg (20 g)	0.15 mg (20 g)
Minimum weight (USP, tolerance = 0.10%) ³⁾	160 mg	160 mg
Minimum weight (tolerance = 1%) ³⁾	16 mg	16 mg
Settling time	2 s	2 s
Adjustment	Internal	External
Balance dimensions (W × D × H)	210 × 344 × 344 mm	210 × 344 × 344 mm
Weighing pan diameter	90 mm	90 mm
Usable height of draft shield	238 mm	238 mm
Balance weight	4.7 kg	4.5 kg
Weights for routine testing		
Weights (OIML class)	2 g (F2)/ 50 g (F2)	2 g (F2)/ 50 g (F2)
Weights (ASTM class)	2 g (ASTM 1)/ 50 g (ASTM 1)	2 g (ASTM 1)/ 50 g (ASTM 1)

¹⁾ after sensitivity adjustment

²⁾ In the temperature range +10 °C – +30 °C

³⁾ determined at 5% load, k = 2

	ME104	ME104E
Limit values		
Capacity	120 g	120 g
Nominal load	100 g	100 g
Readability	0.1 mg	0.1 mg
Repeatability	0.1 mg	0.1 mg
Linearity deviation	0.2 mg	0.2 mg
Eccentricity deviation (at test load)	0.3 mg (50 g)	0.3 mg (50 g)
Sensitivity offset (at nominal load) ¹⁾	0.8 mg	0.8 mg
Sensitivity temperature drift ²⁾	0.0002 %/°C	0.0002 %/°C
Typical values		
Repeatability	0.08 mg	0.08 mg
Linearity deviation	0.06 mg	0.06 mg
Eccentricity deviation (at test load)	0.15 mg (50 g)	0.15 mg (50 g)
Minimum weight (USP, tolerance = 0.10%) ³⁾	160 mg	160 mg
Minimum weight (tolerance = 1%) ³⁾	16 mg	16 mg
Settling time	2 s	2 s
Adjustment	Internal	External
Balance dimensions (W × D × H)	210 × 344 × 344 mm	210 × 344 × 344 mm
Weighing pan diameter	90 mm	90 mm
Usable height of draft shield	238 mm	238 mm
Balance weight	4.7 kg	4.5 kg
Weights for routine testing		
Weights (OIML class)	5 g (F2)/ 100 g (F2)	5 g (F2)/ 100 g (F2)
Weights (ASTM class)	5 g (ASTM 1)/ 100 g (ASTM 1)	5 g (ASTM 1)/ 100 g (ASTM 1)

¹⁾ after sensitivity adjustment

²⁾ In the temperature range +10 °C – +30 °C

³⁾ determined at 5% load, k = 2

	ME204	ME204E
Limit values		
Capacity	220 g	220 g
Nominal load	200 g	200 g
Readability	0.1 mg	0.1 mg
Repeatability	0.1 mg	0.1 mg
Linearity deviation	0.2 mg	0.2 mg
Eccentricity deviation (at test load)	0.4 mg (100 g)	0.4 mg (100 g)
Sensitivity offset (at nominal load) ¹⁾	1 mg	1 mg
Sensitivity temperature drift ²⁾	0.0002 %/°C	0.0003 %/°C
Typical values		
Repeatability	0.08 mg	0.08 mg
Linearity deviation	0.06 mg	0.06 mg
Eccentricity deviation (at test load)	0.15 mg (100 g)	0.15 mg (100 g)
Minimum weight (USP, tolerance = 0.10%) ³⁾	160 mg	160 mg
Minimum weight (tolerance = 1%) ³⁾	16 mg	16 mg
Settling time	2 s	2 s
Adjustment	Internal	External
Balance dimensions (W × D × H)	210 × 344 × 344 mm	210 × 344 × 344 mm
Weighing pan diameter	90 mm	90 mm
Usable height of draft shield	238 mm	238 mm
Balance weight	4.7 kg	4.5 kg
Weights for routine testing		
Weights (OIML class)	10 g (F2)/ 200 g (F2)	10 g (F2)/ 200 g (F2)
Weights (ASTM class)	10 g (ASTM 1)/ 200 g (ASTM 1)	10 g (ASTM 1)/ 200 g (ASTM 1)

¹⁾ after sensitivity adjustment

²⁾ In the temperature range +10 °C – +30 °C

³⁾ determined at 5% load, k = 2

10.2.3 Balances with readability of 1 mg with draft shield

	ME103	ME103E
Limit values		
Capacity	120 g	120 g
Nominal load	100 g	100 g
Readability	1 mg	1 mg
Repeatability	1 mg	1 mg
Linearity deviation	2 mg	2 mg
Eccentricity deviation (at test load)	4 mg (50 g)	4 mg (200 g)
Sensitivity offset (at nominal load) ¹⁾	8 mg	8 mg
Sensitivity temperature drift ²⁾	0.0003 %/°C	0.0003 %/°C
Typical values		
Repeatability	0.7 mg	0.7 mg
Linearity deviation	0.6 mg	0.6 mg
Eccentricity deviation (at test load)	1.5 mg (50 g)	1.5 mg (200 g)
Sensitivity offset (at nominal load) ¹⁾	5 mg	5 mg
Minimum weight (USP, tolerance = 0.10%) ³⁾	2.1 g	2.1 g
Minimum weight (tolerance = 1%) ³⁾	140 mg	140 mg
Settling time	2 s	2 s
Adjustment	Internal	External
Balance dimensions (W × D × H)	210 × 319 × 289 mm	210 × 319 × 289 mm
Weighing pan diameter	120 mm	120 mm
Usable height of draft shield	172.6 mm	172.6 mm
Balance weight	4.6 kg	4.6 kg
Weights for routine testing		
Weights (OIML class)	5 g (F2)/ 100 g (F2)	5 g (F2)/ 100 g (F2)
Weights (ASTM class)	5 g (ASTM 1)/ 100 g (ASTM 1)	5 g (ASTM 1)/ 100 g (ASTM 1)

¹⁾ after sensitivity adjustment

²⁾ In the temperature range +10 °C – +30 °C

³⁾ determined at 5% load, k = 2

	ME203	ME203E
Limit values		
Capacity	220 g	220 g
Nominal load	200 g	200 g
Readability	1 mg	1 mg
Repeatability	1 mg	1 mg
Linearity deviation	2 mg	2 mg
Eccentricity deviation (at test load)	4 mg (100 g)	4 mg (200 g)
Sensitivity offset (at nominal load) ¹⁾	8 mg	8 mg
Sensitivity temperature drift ²⁾	0.0003 %/°C	0.0003 %/°C
Typical values		
Repeatability	0.7 mg	0.7 mg
Linearity deviation	0.6 mg	0.6 mg
Eccentricity deviation (at test load)	1.5 mg (100 g)	1.5 mg (200 g)
Sensitivity offset (at nominal load) ¹⁾	5 mg	5 mg
Minimum weight (USP, tolerance = 0.10%) ³⁾	2.1 g	1.4 g
Minimum weight (tolerance = 1%) ³⁾	140 mg	140 mg
Settling time	2 s	2 s
Adjustment	Internal	External
Balance dimensions (W × D × H)	210 × 319 × 289 mm	210 × 319 × 289 mm
Weighing pan diameter	120 mm	120 mm
Usable height of draft shield	172.6 mm	172.6 mm
Balance weight	4.6 kg	4.4 kg
Weights for routine testing		
Weights (OIML class)	10 g (F2)/ 200 g (F2)	10 g (F2)/ 200 g (F2)
Weights (ASTM class)	10 g (ASTM 1)/ 200 g (ASTM 1)	10 g (ASTM 1)/ 200 g (ASTM 1)

¹⁾ after sensitivity adjustment

²⁾ In the temperature range +10 °C – +30 °C

³⁾ determined at 5% load, k = 2

	ME303	ME303E
Limit values		
Capacity	320 g	320 g
Nominal load	300 g	300 g
Readability	1 mg	1 mg
Repeatability	1 mg	1 mg
Linearity deviation	2 mg	2 mg
Eccentricity deviation (at test load)	4 mg (100 g)	4 mg (200 g)
Sensitivity offset (at nominal load) ¹⁾	8 mg	8 mg
Sensitivity temperature drift ²⁾	0.0003 %/°C	0.0003 %/°C
Typical values		
Repeatability	0.7 mg	0.7 mg
Linearity deviation	0.6 mg	0.6 mg
Eccentricity deviation (at test load)	1.5 mg (100 g)	1.5 mg (200 g)
Sensitivity offset (at nominal load) ¹⁾	5 mg	5 mg
Minimum weight (USP, tolerance = 0.10%) ³⁾	2.1 g	2.1 g
Minimum weight (tolerance = 1%) ³⁾	140 mg	140 mg
Settling time	2 s	2 s
Adjustment	Internal	External
Balance dimensions (W × D × H)	210 × 319 × 289 mm	210 × 319 × 289 mm
Weighing pan diameter	120 mm	120 mm
Usable height of draft shield	172.6 mm	172.6 mm
Balance weight	4.6 kg	4.6 kg
Weights for routine testing		
Weights (OIML class)	10 g (F2)/ 200 g (F2)	10 g (F2)/ 200 g (F2)
Weights (ASTM class)	10 g (ASTM 1)/ 200 g (ASTM 1)	10 g (ASTM 1)/ 200 g (ASTM 1)

¹⁾ after sensitivity adjustment

²⁾ In the temperature range +10 °C – +30 °C

³⁾ determined at 5% load, k = 2

	ME403	ME403E
Limit values		
Capacity	420 g	420 g
Nominal load	400 g	400 g
Readability	1 mg	1 mg
Repeatability	1 mg	1 mg
Linearity deviation	2 mg	2 mg
Eccentricity deviation (at test load)	4 mg (200 g)	4 mg (200 g)
Sensitivity offset (at nominal load) ¹⁾	8 mg	8 mg
Sensitivity temperature drift ²⁾	0.0003 %/°C	0.0003 %/°C
Typical values		
Repeatability	0.7 mg	0.7 mg
Linearity deviation	0.6 mg	0.6 mg
Eccentricity deviation (at test load)	1.5 mg (200 g)	1.5 mg (200 g)
Sensitivity offset (at nominal load) ¹⁾	5 mg	5 mg
Minimum weight (USP, tolerance = 0.10%) ³⁾	1.4 g	1.4 g
Minimum weight (tolerance = 1%) ³⁾	140 mg	140 mg
Settling time	1.5 s	2 s
Adjustment	Internal	External
Balance dimensions (W × D × H)	210 × 319 × 289 mm	210 × 319 × 289 mm
Weighing pan diameter	120 mm	120 mm
Usable height of draft shield	172.6 mm	172.6 mm
Balance weight	4.6 kg	4.4 kg
Weights for routine testing		
Weights (OIML class)	20 g (F2)/ 200 g (F2)	20 g (F2)/ 200 g (F2)
Weights (ASTM class)	20 g (ASTM 1)/ 200 g (ASTM 1)	20 g (ASTM 1)/ 200 g (ASTM 1)

¹⁾ after sensitivity adjustment

²⁾ In the temperature range +10 °C – +30 °C

³⁾ determined at 5% load, k = 2

10.2.4 Balances with readability of 10 mg / 100 mg

	ME802	ME802E
Limit values		
Capacity	820 g	820 g
Nominal load	800 g	800 g
Readability	10 mg	10 mg
Repeatability	10 mg	10 mg
Linearity deviation	20 mg	20 mg
Eccentricity deviation (at test load)	30 mg (500 g)	30 mg (500 g)
Sensitivity offset (at nominal load) ¹⁾	80 mg	80 mg
Sensitivity temperature drift ²⁾	0.0003 %/°C	0.0003 %/°C
Typical values		
Repeatability	7 mg	7 mg
Linearity deviation	6 mg	6 mg
Eccentricity deviation (at test load)	20 mg (500 g)	20 mg (500 g)
Sensitivity offset (at nominal load) ¹⁾	70 mg	70 mg
Minimum weight (USP, tolerance = 0.10%) ³⁾	14 g	14 g
Minimum weight (tolerance = 1%) ³⁾	1.4 g	1.4 g
Settling time	1 s	1 s
Adjustment	Internal	External
Balance dimensions (W × D × H)	200 × 319 × 100 mm	200 × 319 × 100 mm
Weighing pan dimensions (W × D)	180 × 180 mm	180 × 180 mm
Balance weight	3.7 kg	3.1 kg
Weights for routine testing		
Weights (OIML class)	20 g (F2)/ 500 g (F2)	20 g (F2)/ 500 g (F2)
Weights (ASTM class)	20 g (ASTM 1)/ 500 g (ASTM 1)	20 g (ASTM 1)/ 500 g (ASTM 1)

¹⁾ after sensitivity adjustment

²⁾ In the temperature range +10 °C – +30 °C

³⁾ determined at 5% load, k = 2

	ME1002	ME1002E
Limit values		
Capacity	1200 g	1200 g
Nominal load	1000 g	1000 g
Readability	10 mg	10 mg
Repeatability	10 mg	10 mg
Linearity deviation	20 mg	20 mg
Eccentricity deviation (at test load)	40 mg (500 g)	40 mg (500 g)
Sensitivity offset (at nominal load) ¹⁾	80 mg	80 mg
Sensitivity temperature drift ²⁾	0.0003 %/°C	0.0003 %/°C
Typical values		
Repeatability	7 mg	7 mg
Linearity deviation	6 mg	6 mg
Eccentricity deviation (at test load)	20 mg (500 g)	20 mg (500 g)
Sensitivity offset (at nominal load) ¹⁾	70 mg	70 mg
Minimum weight (USP, tolerance = 0.10%) ³⁾	14 g	14 g
Minimum weight (tolerance = 1%) ³⁾	1.4 g	1.4 g
Settling time	1 s	1 s
Adjustment	Internal	External
Balance dimensions (W × D × H)	200 × 319 × 100 mm	200 × 319 × 100 mm
Weighing pan dimensions (W × D)	180 × 180 mm	180 × 180 mm
Balance weight	3.7 kg	3.1 kg
Weights for routine testing		
Weights (OIML class)	50 g (F2)/ 1000 g (F2)	50 g (F2)/ 1000 g (F2)
Weights (ASTM class)	50 g (ASTM 1)/ 1000 g (ASTM 1)	50 g (ASTM 1)/ 1000 g (ASTM 1)

¹⁾ after sensitivity adjustment

²⁾ In the temperature range +10 °C – +30 °C

³⁾ determined at 5% load, k = 2

	ME2002	ME2002E
Limit values		
Capacity	2200 g	2200 g
Nominal load	2000 g	2000 g
Readability	10 mg	10 mg
Repeatability	10 mg	10 mg
Linearity deviation	20 mg	20 mg
Eccentricity deviation (at test load)	40 mg (1000 g)	40 mg (1000 g)
Sensitivity offset (at nominal load) ¹⁾	80 mg	80 mg
Sensitivity temperature drift ²⁾	0.0003 %/°C	0.0003 %/°C
Typical values		
Repeatability	7 mg	7 mg
Linearity deviation	6 mg	6 mg
Eccentricity deviation (at test load)	20 mg (1000 g)	20 mg (1000 g)
Sensitivity offset (at nominal load) ¹⁾	70 mg	70 mg
Minimum weight (USP, tolerance = 0.10%) ³⁾	14 g	14 g
Minimum weight (tolerance = 1%) ³⁾	1.4 g	1.4 g
Settling time	1 s	1 s
Adjustment	Internal	External
Balance dimensions (W × D × H)	200 × 319 × 100 mm	200 × 319 × 100 mm
Weighing pan dimensions (W × D)	180 × 180 mm	180 × 180 mm
Balance weight	3.7 kg	3.1 kg
Weights for routine testing		
Weights (OIML class)	100 g (F2)/ 2000 g (F2)	100 g (F2)/ 2000 g (F2)
Weights (ASTM class)	100 g (ASTM 1)/ 2000 g (ASTM 1)	100 g (ASTM 1)/ 2000 g (ASTM 1)

¹⁾ after sensitivity adjustment

²⁾ In the temperature range +10 °C – +30 °C

³⁾ determined at 5% load, k = 2

	ME3002	ME3002E
Limit values		
Capacity	3200 g	3200 g
Nominal load	3000 g	3000 g
Readability	10 mg	10 mg
Repeatability	10 mg	10 mg
Linearity deviation	20 mg	20 mg
Eccentricity deviation (at test load)	40 mg (1000 g)	40 mg (1000 g)
Sensitivity offset (at nominal load) ¹⁾	80 mg	80 mg
Sensitivity temperature drift ²⁾	0.0003 %/°C	0.0003 %/°C
Typical values		
Repeatability	7 mg	7 mg
Linearity deviation	6 mg	6 mg
Eccentricity deviation (at test load)	20 mg (1000 g)	20 mg (1000 g)
Sensitivity offset (at nominal load) ¹⁾	70 mg	70 mg
Minimum weight (USP, tolerance = 0.10%) ³⁾	14 g	14 g
Minimum weight (tolerance = 1%) ³⁾	1.4 g	1.4 g
Settling time	1 s	1 s
Adjustment	Internal	External
Balance dimensions (W × D × H)	200 × 319 × 100 mm	200 × 319 × 100 mm
Weighing pan dimensions (W × D)	180 × 180 mm	180 × 180 mm
Balance weight	3.7 kg	3.1 kg
Weights for routine testing		
Weights (OIML class)	100 g (F2)/ 2000 g (F2)	100 g (F2)/ 2000 g (F2)
Weights (ASTM class)	100 g (ASTM 1)/ 2000 g (ASTM 1)	100 g (ASTM 1)/ 2000 g (ASTM 1)

¹⁾ after sensitivity adjustment

²⁾ In the temperature range +10 °C – +30 °C

³⁾ determined at 5% load, k = 2

	ME4002	ME4002E
Limit values		
Capacity	4200 g	4200 g
Nominal load	4000 g	4000 g
Readability	10 mg	10 mg
Repeatability	10 mg	10 mg
Linearity deviation	20 mg	20 mg
Eccentricity deviation (at test load)	40 mg (2000 g)	40 mg (2000 g)
Sensitivity offset (at nominal load) ¹⁾	80 mg	80 mg
Sensitivity temperature drift ²⁾	0.0003 %/°C	0.0003 %/°C
Typical values		
Repeatability	7 mg	7 mg
Linearity deviation	6 mg	6 mg
Eccentricity deviation (at test load)	20 mg (2000 g)	20 mg (2000 g)
Sensitivity offset (at nominal load) ¹⁾	70 mg	70 mg
Minimum weight (USP, tolerance = 0.10%) ³⁾	14 g	14 g
Minimum weight (tolerance = 1%) ³⁾	1.4 g	1.4 g
Settling time	1 s	1 s
Adjustment	Internal	External
Balance dimensions (W × D × H)	200 × 319 × 100 mm	200 × 319 × 100 mm
Weighing pan dimensions (W × D)	180 × 180 mm	180 × 180 mm
Balance weight	3.7 kg	3.1 kg
Weights for routine testing		
Weights (OIML class)	200 g (F2)/ 2000 g (F2)	200 g (F2)/ 2000 g (F2)
Weights (ASTM class)	200 g (ASTM 4)/ 2000 g (ASTM 4)	200 g (ASTM 4)/ 2000 g (ASTM 4)

¹⁾ after sensitivity adjustment

²⁾ In the temperature range +10 °C – +30 °C

³⁾ determined at 5% load, k = 2

	ME4001	ME4001E
Limit values		
Capacity	4200 g	4200 g
Nominal load	4000 g	4000 g
Readability	100 mg	100 mg
Repeatability	100 mg	100 mg
Linearity deviation	200 mg	200 mg
Eccentricity deviation (at test load)	100 mg (2000 g)	100 mg (2000 g)
Sensitivity offset (at nominal load) ¹⁾	100 mg	100 mg
Sensitivity temperature drift ²⁾	0.0003 %/°C	0.0003 %/°C
Typical values		
Repeatability	70 mg	70 mg
Linearity deviation	60 mg	60 mg
Eccentricity deviation (at test load)	40 mg (2000 g)	40 mg (2000 g)
Sensitivity offset (at nominal load) ¹⁾	80 mg	70 mg
Minimum weight (USP, tolerance = 0.10%) ³⁾	14 g	14 g
Minimum weight (tolerance = 1%) ³⁾	1.4 g	1.4 g
Settling time	1 s	1 s
Adjustment	Internal	External
Balance dimensions (W × D × H)	200 × 319 × 100 mm	200 × 319 × 100 mm
Weighing pan dimensions (W × D)	180 × 180 mm	180 × 180 mm
Balance weight	3.7 kg	3.1 kg
Weights for routine testing		
Weights (OIML class)	200 g (F2)/ 2000 g (F2)	200 g (F2)/ 2000 g (F2)
Weights (ASTM class)	200 g (ASTM 4)/ 2000 g (ASTM 4)	200 g (ASTM 4)/ 2000 g (ASTM 4)

¹⁾ after sensitivity adjustment

²⁾ In the temperature range +10 °C – +30 °C

³⁾ determined at 5% load, k = 2

10.3.2 Balances with readability of 1 mg with draft shield low

Models:
ME103
ME103E
ME203
ME203E
ME303
ME303E
ME403
ME403E

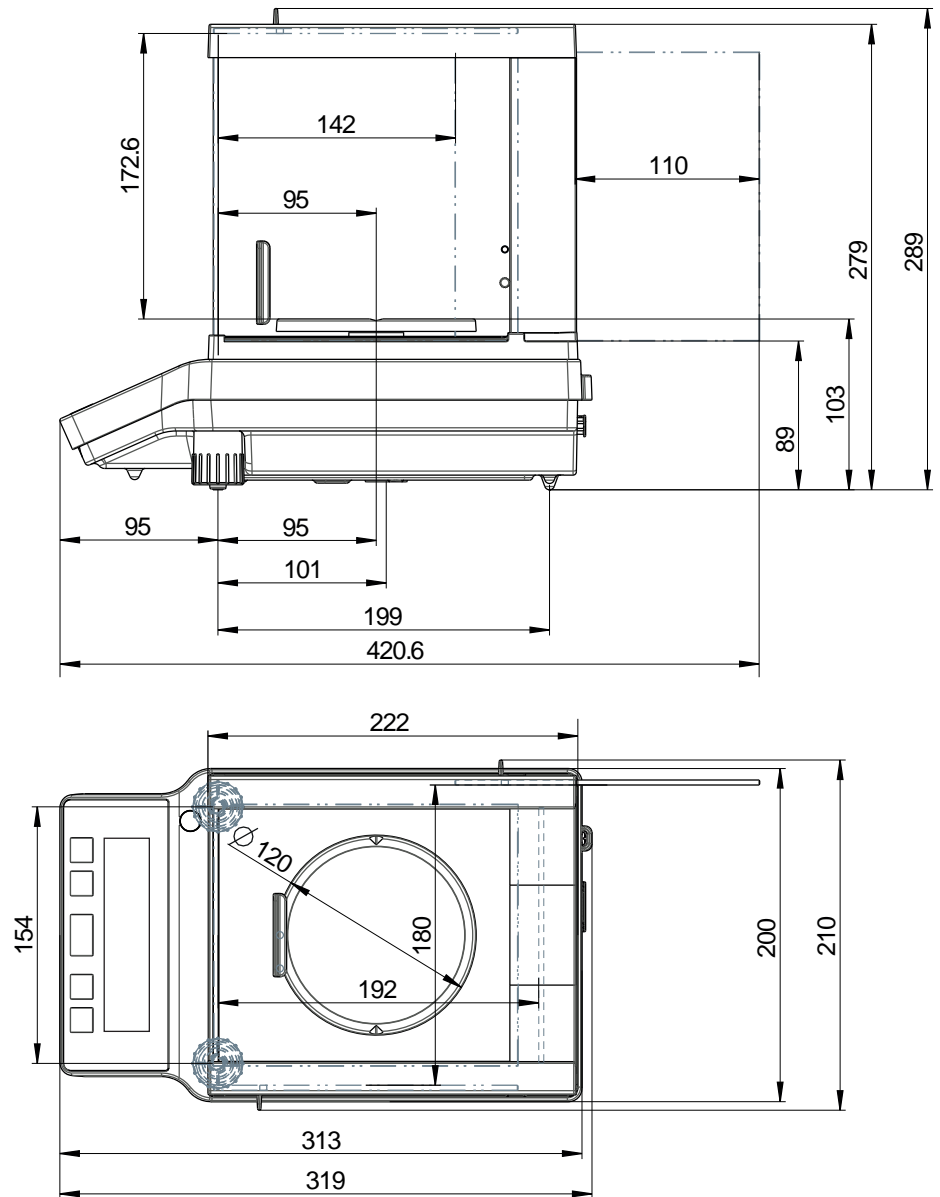

10.3.3 Balances with readability of 10 mg / 100 mg

Models:

- ME802
- ME802E
- ME1002
- ME1002E
- ME2002
- ME2002E
- ME3002
- ME3002E
- ME4002
- ME4002E
- ME4001
- ME4001E

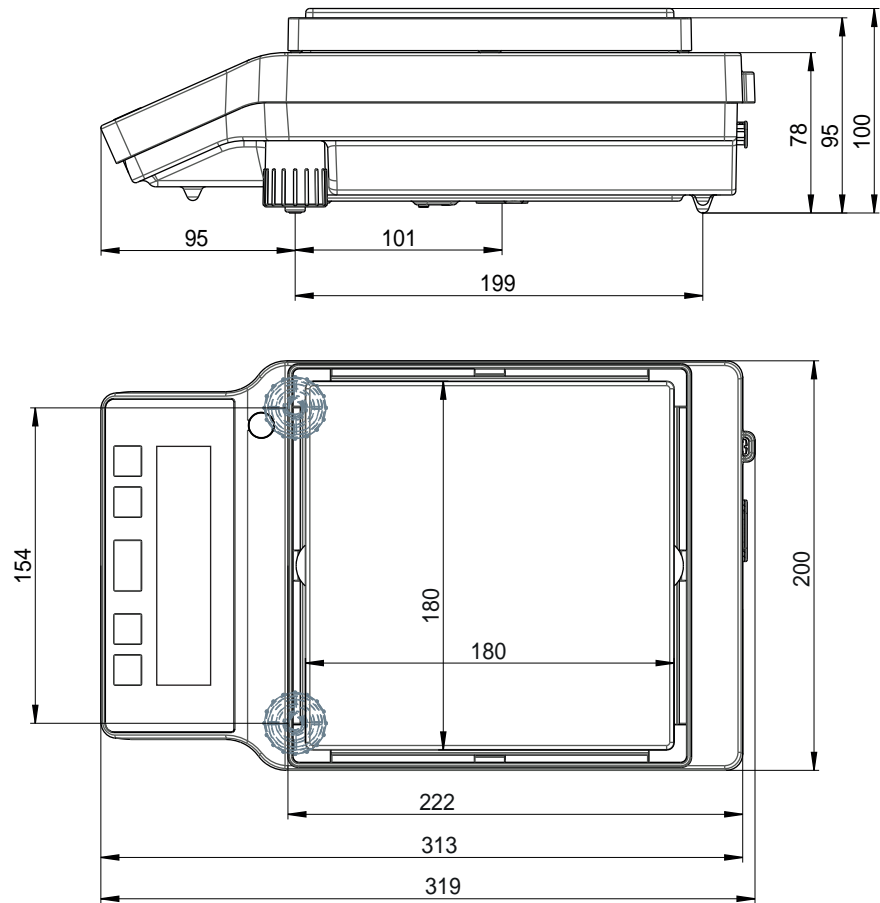

10.4 Interface specification

10.4.1 RS232C interface

Each balance is equipped with an RS232C Interface as standard for the attachment of a peripheral device, e.g., printer or computer.

Schematic	Item	Specification
	Interface type	Voltage interface according to EIA RS232C/ DIN66020 CCITT V24/V.28)
	Max. cable length	15 m
	Signal level	Outputs: +5 V ... +15 V (RL = 3–7 kΩ) –5 V ... –15 V (RL = 3–7 kΩ) Inputs: +3 V ... +25 V –3 V ... –25 V
	Connector	Sub-D, 9-pole, female
	Operating mode	Full duplex
	Transmission mode	Bit-serial, asynchronous
	Transmission code	ASCII
	Baud rates	600, 1200, 2400, 4800, 9600, 19200, 38400 (software selectable)
	Bits/parity	7-bit/none, 7-bit/even, 7-bit/odd, 8-bit/none (software selectable)
	Stop bits	1 stop bit
	Handshake	None, XON/XOFF, RTS/CTS (software selectable)
	End-of-line	<CR><LF>, <CR>, <LF> (software selectable)
	Power supply for 2nd display	+ 12 V, max 40 mA (software selectable, 2nd display mode only)

10.4.2 MT-SICS interface commands and functions

Many of the instruments and balances used have to be able to integrate into a complex computer or data acquisition system.

To easily integrate a balance into a system and utilize its capacity to the full extent, most balance functions are also available as corresponding commands via the data interface.

All new METTLER TOLEDO balances launched on the market support "METTLER TOLEDO Standard Interface Command Set" (MT-SICS). The commands available depend on the functionality of the balance.

For further information, please contact your METTLER TOLEDO representative.











Refer to the MT-SICS Reference Manual which can be downloaded from the Internet at

► www.mt.com/library



11 Accessories and Spare Parts

11.1 Accessories

	Description	Part No.
Printers		
	RS-P25/01 (EMEA) printer with RS232C connection to instrument	11124300
	Paper roll (length: 20 m), set of 5 pcs	00072456
	Paper roll (length: 13 m), self-adhesive, set of 3 pcs	11600388
	Ribbon cartridge, black, set of 2 pcs	00065975
	RS-P25/02 (Asia-Pacific) printer with RS232C connection to instrument	11124310
	Paper roll (length: 20 m), set of 5 pcs	00072456
	Paper roll (length: 13 m), self-adhesive, set of 3 pcs	11600388
	Ribbon cartridge, black, set of 2 pcs	00065975
	RS-P25/03 (Northern America) printer with RS232C connection to instrument	11124320
	Paper roll (length: 20 m), set of 5 pcs	00072456
	Paper roll (length: 13 m), self-adhesive, set of 3 pcs	11600388
	Ribbon cartridge, black, set of 2 pcs	00065975
	RS-P26/01 (EMEA) printer with RS232C connection to instrument (with date and time)	11124303
	Paper roll (length: 20 m), set of 5 pcs	00072456
	Paper roll, self-adhesive (length: 13 m), set of 3 pcs	11600388
	Ribbon cartridge, black, set of 2 pcs	00065975
	RS-P26/02 (Asia-Pacific) printer with RS232C connection to instrument (with date and time)	11124313
	Paper roll (length: 20 m), set of 5 pcs	00072456
	Paper roll (length: 13 m), self-adhesive, set of 3 pcs	11600388
	Ribbon cartridge, black, set of 2 pcs	00065975
	RS-P26/03 (Northern America) printer with RS232C connection to instrument (with date and time)	11124323
	Paper roll (length: 20 m), set of 5 pcs	00072456
	Paper roll, self-adhesive (length: 13 m), set of 3 pcs	11600388
	Ribbon cartridge, black, set of 2 pcs	00065975

	RS-P28/01 (EMEA) printer with RS232C connection to instrument (with date, time and applications)	11124304
	Paper roll (length: 20 m), set of 5 pcs	00072456
	Paper roll, self-adhesive (length: 13 m), set of 3 pcs	11600388
	Ribbon cartridge, black, set of 2 pcs	00065975
	RS-P28/02 (Asia-Pacific) printer with RS232C connection to instrument (with date, time and applications)	11124314
	Paper roll (length: 20 m), set of 5 pcs	00072456
	Paper roll (length: 13 m), self-adhesive, set of 3 pcs	11600388
	Ribbon cartridge, black, set of 2 pcs	00065975
	RS-P28/03 (Northern America) printer with RS232C connection to instrument (with date, time and applications)	11124324
	Paper roll (length: 20 m), set of 5 pcs	00072456
	Paper roll, self-adhesive (length: 13 m), set of 3 pcs	11600388
	Ribbon cartridge, black, set of 2 pcs	00065975

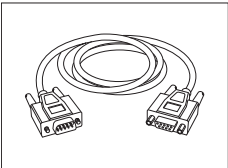
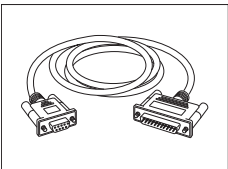
Cables for RS232C interface

	RS9 – RS9 (m/f): connection cable for PC, length = 1 m	11101051
	RS9 – RS25 (m/f): connection cable for PC, length = 2 m	11101052
	USB-RS232 cable (to connect a balance via RS232C to a USB port)	64088427

Density determination

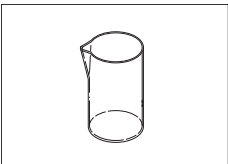
	Density Kit Advanced & Standard for balance models with a readability of 0.1 mg / 1 mg	30535760
	Glass beaker, height 100 mm, \varnothing 60 mm	00238166

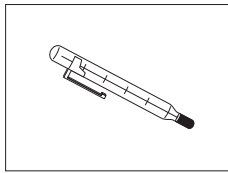

Calibrated thermometer with certificate

11132685

Weighing pans

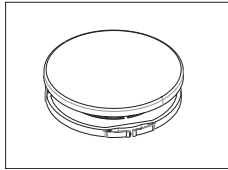

Set of weighing pan \varnothing 160 mm with pan support for balances with readability of 10 mg and 100 mg using draft shield

30042896

Draft shields

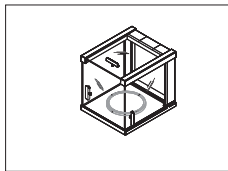

Draft shield low with sliding doors, usable height 170 mm.

30042884

- for balances 0.01 mg or 1 mg
- for balances 10 mg or 100 mg, weighing pan \varnothing 160 mm is needed (#30042896)

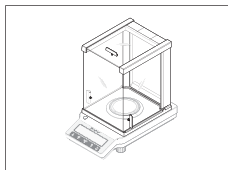

Draft shield high with sliding doors, usable height 235 mm

30037731

- for balances 0.1 mg or 1 mg
- for balances 10 mg or 100 mg, weighing pan \varnothing 160 mm is needed (#30042896)

Auxiliary displays



RS232C auxiliary display AD-RS-M7

12122381

Pan protections

Protective covers

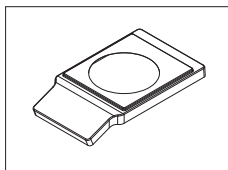

Protective cover for models with readability of 0.01 mg / 0.1 mg

30241549

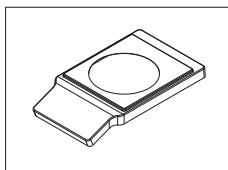

Protective cover for models with readability of 1 mg / 100 mg

30241560

Dust covers

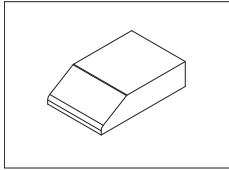

Dust cover for models without draft shield

30029051

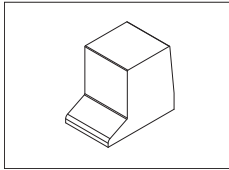

Dust cover for models with draft shield low (170 mm)

30029050

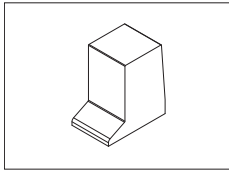

Dust cover for models with draft shield high (235 mm)

30029049

Anti-theft devices



Anti-theft cable with lock

11600361

Software



EasyDirect Balance is an application software to collect, analyze, store and export balance measurement and device data on PC.

License EasyDirect Balance for 10 Instruments

30540473

License EasyDirect Balance for 3 Instruments

30539323

Various

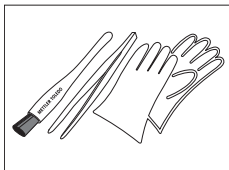

Tool kit, contains brush, tweezers and gloves

30046403

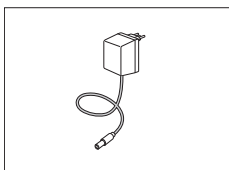

AC/DC universal adapter (EU, USA, AU, UK) 100–240 VAC, 50/60 Hz, 0.5 A, 12 VDC 1 A

11120270

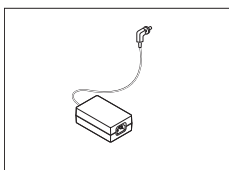

AC/DC adapter (without power cable) 100–240 V AC, 0.8 A, 50/60 Hz, 12 V DC 2.5 A

11107909

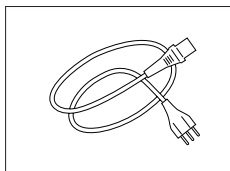

Country-specific 3-Pin power cable with grounding conductor.

Power cable AU	00088751
Power cable BR	30015268
Power cable CH	00087920
Power cable CN	30047293
Power cable DK	00087452
Power cable EU	00087925
Power cable GB	00089405
Power cable IL	00225297
Power cable IN	11600569
Power cable IT	00087457
Power cable JP	11107881
Power cable TH, PE	11107880
Power cable US	00088668
Power cable ZA	00089728

Adjustment weights



OIML / ASTM Weights (with calibration certificate)
see <http://www.mt.com/weights>

11.2 Spare parts

Balances with readability of 0.1 mg / 0.01 mg

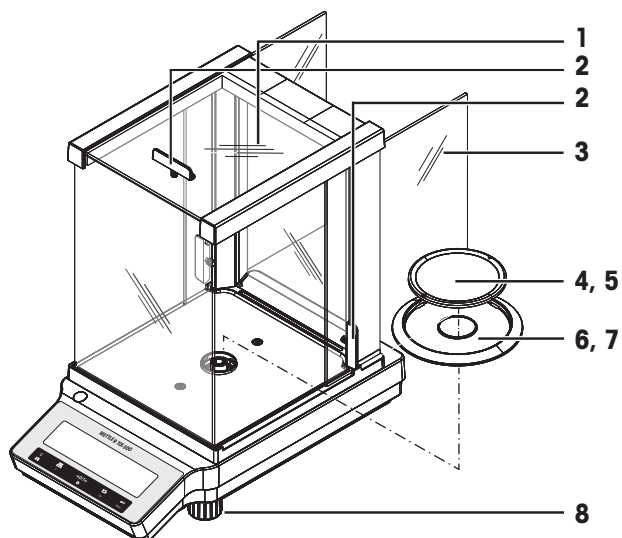

	Order no.	Designation	Remarks
1	30037733	Door top draft shield	Material: Glass; Including: Door handle
2	30037736	Door handles draft shield	Including: 2 door handles
3	30037732	Door left and right draft shield, set	Material: Glass; Including: 2 Door handles
4	30098665	Weighing pan Ø 80 mm	Including: Pan support
5	30037737	Weighing pan Ø 90 mm	Including: Pan support
6	30216708	Draft protection ring	For weighing pan Ø 80 mm
7	12122043	Draft protection ring	For weighing pan Ø 90 mm
8	30037744	Leveling foot	Including: 2 leveling feet

Balances with readability of 1 mg

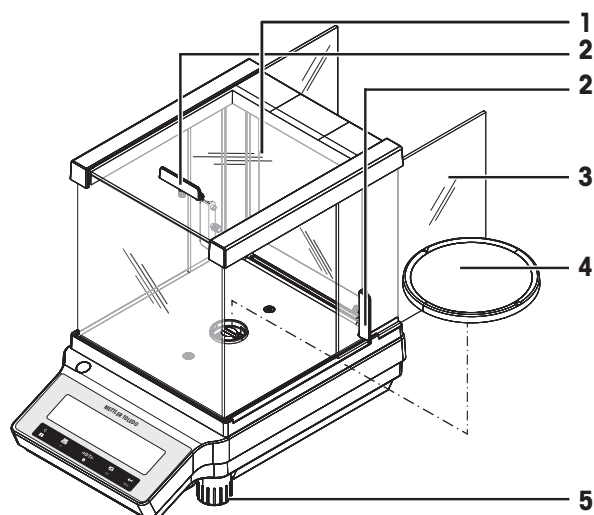

	Order no.	Designation	Remarks
1	30037733	Door top draft shield	Material: Glass; Including: Door handle
2	30037736	Door handles draft shield	Including: 2 door handles
3	30042885	Door left and right draft shield, set	Material: Glass; Including: 2 door handles
4	30042889	Weighing pan Ø 120 mm	Including: Pan support
5	30037744	Leveling foot	Including: 2 leveling feet

ME Balances with readability of 10 mg / 100 mg

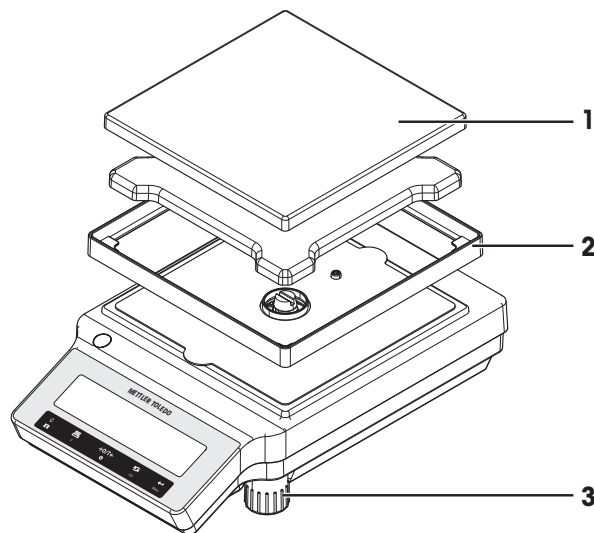

	Order no.	Designation	Remarks
1	30535713	Weighing pan 180 x 180 mm	Excluding: Pan support
2	30042897	Draft protection frame 180 x180 mm	–
3	30037744	Leveling foot	Including: 2 leveling feet

Miscellaneous

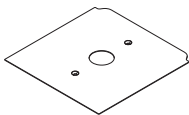

	Order no.	Designation	Remarks
1	30037739	Bottom plate draft shield	–

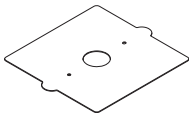

	Order no.	Designation	Remarks
1	30042901	Bottom plate	Excluding: Screws

12 Disposal

In conformance with the European Directive 2012/19/EU on Waste Electrical and Electronic Equipment (WEEE) this device may not be disposed of in domestic waste. This also applies to countries outside the EU, per their specific requirements.



Please dispose of this product in accordance with local regulations at the collecting point specified for electrical and electronic equipment. If you have any questions, please contact the responsible authority or the distributor from which you purchased this device. Should this device be passed on to other parties, the content of this regulation must also be related.

Index

Numerics

1/10 d 31

A

AC/DC adapter 77
Accessories 96
Adjusting 21
Adjustment 22
Adjustment lock 33
Advanced menu 29
Application check weighing 44
Application density 59
Application division factor weighing 57
Application dynamic weighing 53
Application formulation 48
Application icons 10
Application multiplication factor weighing 55
Application percent weighing 42
Application piece counting 39
Application statistics 46
Application totaling 51
Applications 11
Auto print 36
Automatic standby 34
Automatic zero setting 34
Autozero 34
Average (Statistics) 46

B

Backlight 34
Basic menu 29, 31
Basic principles for operation 11
Baudrate 37
Below-the-balance weighing 27
Bit/Parity 37

C

Cancel 12
Change settings 12
Char set 38
Check weighing 44
Cleaning 68
Closing the menu 12
Components 8
Conventions and symbols 3
Customer fine adjustment 22

D

Data communication format 36
Date 20, 31
Date format 33
Density 59
Density kit 59, 97
Density of distilled water 63
Density table for ethanol 63
Dimensions 92
Display 35
Display increment 31
Display panel 10
Disposal 104
Distilled water 63
Division factor weighing 57
Draft shield 15, 68, 70
Dynamic weighing 53

E

End of line 38
Environment 33
Environmental conditions 77
Ethanol 63
External weight 22

F

Factor weighing 55, 57
Fill up 49
Formulation 48
Function fill up 49
Function PC-Direct 64

H

Handles 70
Handshake 38
Header 35
Host 35

I

Icons 10
Identification 32
In use cover
 see protective cover 17
Input principle 12
Installing
 Handles 70

Installing the components	15	Power supply	77
Interface		Print	26
MT-SICS	95	Print menu	32
Interface menu	30, 35	Printer	35
Interface RS232C	35, 95	Protect	30
Internal weight	21	Protection and standards	77
Interval	38	Protective cover	17
Introduction	3		
L		R	
Level indicator	19	Recall	25, 33
Leveling	19	Reset	32
Leveling the balance	19	RS232C interface	35, 95
Line feed	36		
Liquids	61	S	
Location	14	Safety information	
Lock adjustment	33	Signal words	5
		Warning symbols	5
M		Safety precautions	5
Main menu	30	Saving settings	12
Manual adjustment with external weight	22	Scope of delivery	14
Manual adjustment with internal weight	21	Select menu	11
Materials	77	Select menu topic	12
Menu	30	Selecting the location	14
Menu advanced	29	Selecting weighing application	11
Menu basic	29, 31	Service	34, 68
Menu interface	30, 35	Service date reset	34
Menu operation	11	Service icon	34
Menu protection	30	Service reminder	34
Menu topic	12, 30	Set identification	32
MT-SICS	95	Setting date and time	20
Multiplication factor weighing	55	Setting up the balance	14
		Signal words	5
N		Signature line	36
Net	25	Single	36
Numerical values	12	Sinker	59
		Solids	59
O		Spare parts	103
ON / OFF	26	Standard deviation (Statistics)	46
Operating temperature	19	Standby	34
Overview	8	Statistics	46
		Status icons	10, 76
P		Status messages	76
PC-DIR	35	Stop bit	38
PC-Direct	64	Submenu	12
Percent weighing	42	Switching off	26
Performing a simple weighing	24	Switching weight units	25
Piece counting	39	Symbols and conventions	3

T

Taring	25
Technical data	77
Time	20, 31
Time format	33
Topic	12, 30
Totaling	51
Transmit data	26
Transport over short distances	27
Transporting the balance	27

U

Unit	31
------	----

W

Warm-up time	19
Warning symbols	5
Weighing application	11
Weighing-in aid	26
Weight unit	25, 31

Z

Zero print	36
Zero range	34
Zero setting	24
Zeroing	34

GWP®

Good Weighing Practice™

GWP® is the global weighing standard, ensuring consistent accuracy of weighing processes, applicable to all equipment from any manufacturer. It helps to:

- Choose the appropriate balance or scale
- Calibrate and operate your weighing equipment with security
- Comply with quality and compliance standards in laboratory and manufacturing

 www.mt.com/GWP

www.mt.com/balances

For more information

Mettler-Toledo GmbH

Im Langacher 44
8606 Greifensee, Switzerland
www.mt.com/contact

Subject to technical changes.
© Mettler-Toledo GmbH 07/2020
30045655G en



30045655